

# Appendix B

## FOG and Sewer Lateral Documents

1. LGVSD Ordinance Code provisions related to FOG
2. List of FOG “Hot Spots”
3. CMSA FOG Inspection Status Reports
4. Ordinance 153 - Lateral Rehabilitation Assistance Program
5. Ordinance 180 - Sewer Lateral Program
6. Uniform LGVSD-SRSD Standard Specifications for Lateral Sewers

This page intentionally blank

## CHAPTER 4

### FATS, OILS, AND GREASE (FOG) ORDINANCE OF THE LAS GALLINAS VALLEY SANITARY DISTRICT

ARTICLE I. INTRODUCTION. This Ordinance shall be known as the "Fats, Oils and Grease (FOG) Ordinance of the Las Gallinas Valley Sanitary District" and may be so cited and pleaded. This Ordinance is adopted pursuant to provisions of Section 6400 et seq. of the Health and Safety Code of the State of California.

ARTICLE II. PURPOSE AND POLICY.

Section 201. Sanitary sewer overflows (SSOs) have recently become a major concern to wastewater agencies throughout the state of California. A frequent cause of SSOs is the blockage of sewer lines due to discharge of fats, oils and grease (FOG) from food preparation and clean-up operations. One of the actions Las Gallinas Valley Sanitary District (District or LGVSD) is taking to prevent SSOs from the sanitary sewers in its service area is to develop and implement a program to reduce the discharge of FOG from restaurants and other food service establishments to levels that will not cause blockage in sewer lines. This program will enable the District to comply with requirements of the California State Water Resources Control Board and the San Francisco Bay Regional Water Quality Control Board.

Section 202. District Ordinance No. 112, adopted by the governing Board of LGVSD in 1995, regulates the discharge of wastes into the District's sanitary sewer system (system). Article IV, Section 402(a) of the Ordinance prohibits the discharge of viscous wastes in amounts which will cause obstruction to the flow in the system. Article V, Section 501(b)10 and Article VIII, Section 804 give the District authority to require sewer users to install pretreatment equipment as necessary to bring their discharges into compliance with the Ordinance. Article V, Section 501(b)7; Article V, Section 501(b)9; and Article VIII, Section 801 give the District staff authority to perform inspections on the premises of sewer users and to review user records relevant to sewer discharge.

Section 203. Upon adoption of this Ordinance, all food service establishments (FSE's) subject to this Ordinance, as further defined in Article V of this Ordinance, shall be designated as "Class III Users," as defined in Section 5.A. of Ordinance No. 112. This designation is based

on the discharge of FOG as discussed herein.

ARTICLE III. JURISDICTION. The provisions of this Ordinance shall be in force and applicable within the service area which encompasses the jurisdictional boundaries of the Las Gallinas Valley Sanitary District. The District service area is defined in Article V of this Ordinance.

ARTICLE IV. DEFINITIONS.

Section 401. FATS, OILS, AND GREASE (FOG) means any animal- or vegetable-based fats, oils, and grease generated from food preparation, food service, and kitchen clean-up.

Section 402. FOOD SERVICE ESTABLISHMENT (FSE) includes, but is not limited to, any facility preparing and/or serving food for commercial use or sale. This includes restaurants, cafes, lunch counters, cafeterias, hotels, hospitals, convalescent homes, factory or school kitchens, catering kitchens, bakeries, grocery stores with food preparation (excluding stores with only food-warming operations), meat cutting and preparation, and other food-handling facilities not listed above where fats, oils, and grease may be introduced into the sanitary sewers.

Section 403. GREASE REMOVAL DEVICE (GRD) means a device used to remove FOG from kitchen wastes discharged to the sanitary sewer, i.e., a grease interceptor, grease trap, or other mechanical device.

Section 404. GREASE INTERCEPTOR (or INTERCEPTOR) means a GRD consisting of a partitioned vault, with a minimum volume of seven hundred fifty (750) gallons, that is typically installed inground or underground and outside of the building which it serves.

Section 405. GREASE TRAP (or TRAP) means a GRD designed to serve one (1) to four (4) kitchen fixtures. Traps are usually fifty (50) gallons or less in volume and are typically located inside a kitchen, under the sink, or in the floor.

Section 406. LGVSD (or DISTRICT) refers to the Las Gallinas Valley Sanitary District.

Section 407. LGVSD SERVICE AREA (or SERVICE AREA) refers to the area within the jurisdictional boundaries of the Las Gallinas Valley Sanitary District. This includes all parts of the City of San Rafael north of the Puerto Suello ridge (Terra Linda and Civic Center) and some closely adjacent unincorporated areas of Marin County.

Section 408. MAJOR REMODEL means a remodel which includes significant change

to the kitchen and which has a building permit valuation of at least One Hundred Thousand Dollars (\$100,000.00), not including the purchase and installation cost of any grease removal device installed during the remodel.

Section 409. NEW FOOD SERVICE ESTABLISHMENTS means a) A new building which will contain a food service establishment (FSE); b) The installation of an FSE in an existing building which has not previously contained an FSE requiring a Restaurant Plan Check from Marin County Environmental Health Services.

Section 410. SEWER LINE "HOT SPOT" means a location in the sanitary sewer lines where one or more FOG-related sewer overflows have occurred that requires significantly increased maintenance to prevent FOG-related line blockages, and/or where a significant potential exists for FOG-related line blockages to occur. The designation of a "hot spot" will be solely at the discretion of the District, based on the history and characteristics of the location.

Section 411. UNIFORM PLUMBING CODE (UPC) means the "2001 California Plumbing Code" (California Code of Regulations, Title 24, Part 5). This is the UPC currently referenced by the City of San Rafael Municipal Code. If there are future revisions to the UPC that relate to sizing of GRDs, the District reserves the right to use either the present or revised UPC, as appropriate.

Section 412. WORKING CAPACITY means the total volume of solids, water, and grease that a grease interceptor or grease trap contains under normal operating conditions.

ARTICLE V. GREASE REMOVAL DEVICE REQUIREMENTS. All new food service establishments (FSEs), all existing FSEs undergoing a major remodel and all existing FSEs upstream of a "sewer line hot spot" (hot spot) shall have at least one (1) grease removal device (GRD), as specified below. Section 501 of this Ordinance is a table summarizing these requirements.

Section 501. New Food Service Establishments.

- (a) For purposes of this Ordinance, a "new food service establishment" shall be as defined in Article IV of this Ordinance: "a) A new building which will contain a food service establishment (FSE); b) The installation of an FSE in an existing building which has not previously contained an FSE requiring a Restaurant Plan Check from Marin County Environmental Health Services." A business will not be considered a "new FSE" solely on the basis of a change in menu, name, and/or ownership.

- (b) All new FSEs shall install an interceptor sized in accordance with Appendix H of the Uniform Plumbing Code (UPC). Interpretation of Appendix H and the variables used in the sizing calculation shall be at the discretion of the District. It is anticipated that there will be a significant revision of Appendix H by the International Association of Plumbing and Mechanical Officials (IAPMO) during 2006. Although these changes will not be in the UPC currently codified by the City of San Rafael (see Article IV of this Ordinance), the District will accept interceptor sizing based on the new Appendix H.
- (c) The interceptor shall drain all fixtures and equipment in the establishment which may receive FOG, including, but not limited to, utensil sinks, food-preparation sinks, hand-washing sinks in kitchen areas, mop sinks, and floor drains and floor sinks in kitchen and washing areas. The dishwashing machine shall be plumbed to the interceptor, unless specified otherwise by the District. Any discharge to the sanitary sewer from routine cleaning of exhaust hoods and ducts shall be plumbed to the interceptor. No drains from toilets, showers, or other domestic discharges shall be connected to the interceptor.
- (d) Outside refuse areas and/or washing areas must be covered, bermed to prevent discharge to storm drainage, and plumbed to the sanitary sewer in accordance with the requirements of the municipality. These areas shall drain to the kitchen interceptor or to another properly sized interceptor.

Section 502. Major Remodel. Any FSE which is: a) Upstream of a sewer line hot spot, as defined in Article IV of this Ordinance and described in Article V, Section 503 below; and b) Undergoing a major remodel, as defined in Article IV, shall install an interceptor, as described in Article V, Section 501 of this Ordinance. The requirements shall be the same as for a new FSE, except for the following:

- (a) A remodeled FSE may be allowed to not connect some minor kitchen drains, such as hand-washing sinks or floor drains, where connection of these drains to the interceptor would require excessive replumbing. The determination shall be solely at the discretion of the District, on a case-by-case basis. For any drain exempted from connection to the interceptor, the FSE shall maintain employee training and/or signage to prevent discharge of FOG to the drain.
- (b) At the discretion of the District, on a case-by-case basis, a remodeled FSE may be relieved from complying with some of the requirements, specified in Article V,

Section 501 of this Ordinance, regarding outside refuse areas and/or washing areas. At a minimum, facilities and operating practices must be adequate at all times to prevent illegal discharges to storm drainage.

Any FSE which is not upstream of a sewer line hot spot but is undergoing a major remodel, as defined in Article IV of this Ordinance, shall install, at a minimum, one (1) or more grease traps, as required for an existing FSE which is upstream of a hot spot. The requirement for existing FSEs upstream of a hot spot is specified in Article V of this Ordinance.

Section 503. Existing Food Service Establishments – Upstream of "Hot Spot." As defined in Article IV of this Ordinance, a sewer line "hot spot" is a specific location in the sanitary sewer lines where one or more FOG-related sewer overflows have occurred that requires significantly increased maintenance to prevent FOG-related line blockages, and/or where a significant potential exists for FOG-related line blockages to occur. The District shall maintain a current list of the locations designated as hot spots. The list shall reference the evidence supporting each designation. Such evidence may include, but is not limited to, maintenance records, SSO reports, or videotapes. The designation of a hot spot shall be solely at the discretion of the District.

The minimum GRD requirement for any FSE above (upstream) a designated hot spot shall be one (1) or more traps draining at least the utensil sinks and dishwasher prerinse sink (scrap sink). The sizing of the trap(s) shall be as follows:

- (a) For FSEs that do not currently have any GRD in place, the installed trap(s) shall be sized in accordance with Table 102 in Chapter 10 of the UPC, or subsequent revisions, at the discretion of the District. Manufacturer specifications may be used instead of the UPC table, if adequate documentation is provided to assure the Agency that the trap size is appropriate for the fixtures drained.
- (b) Existing FSEs with one or more traps currently installed shall not be required to install a larger trap if the size of the trap is at least seventy (70) percent of the size specified by Table 102 in Chapter 10 of the UPC. Those FSEs with installed traps sized at less than seventy (70) percent of the UPC requirement shall be required to install larger or additional traps to meet the appropriate sizing requirement of the UPC.
- (c) The District reserves the right to require installation of an interceptor, as discussed in Article V, Section 502 of this Ordinance, if such installation is appropriate due to the size, menu, and location of the FSE.

FSEs upstream of a designated hot spot that have a grease trap meeting the requirements in Article V, Section 503 above shall be issued a "conditional wastewater permit." The conditional permit shall authorize the FSE to discharge from their kitchen drains without installation of an interceptor. However, if the District determines that the FSEs grease trap(s) and operating practices are inadequate and the FSE continues to contribute significant quantities of FOG to a downstream sewer line hot spot, the conditional permit shall be revoked and the FSE shall be required to install an interceptor. If the conditional permit is revoked, the FSE shall be subject to the same requirements as described above for an FSE upstream of a hot spot and undergoing a major remodel (Article V, Section 502). Such revocation shall only occur after the District has worked with the permittee to resolve the problem and has documented reasonable evidence that FOG discharges from the FSE are contributing to the hot spot problem.

All grease trap installations (existing traps or new installations) shall comply with all of the following requirements (note that these requirements do not apply to interceptor installations):

- Dishwashing machines shall not drain to a grease trap, unless the FSE can document that the volume and temperature of wash water and rinse water discharged, in combination with any detergent, soap, and/or disinfectant in the water, will not render the trap ineffective.
- All new or existing grease trap installations shall comply with 1014.3 of the UPC. This requires a flow control device, meeting certain criteria, to be installed either on each fixture drain before the trap inlet or at the trap inlet itself.
- For any kitchen drain not connected to the grease trap, the FSE shall maintain employee training and/or signage adequate to prevent discharge of FOG to the drain.
- Installation of specialized grease removal devices of proprietary design, such as the "Big Dipper," will be considered by the District on a case-by-case basis. Approval shall be contingent on demonstration that the device will reliably perform at least as well as a conventional grease trap meeting the requirements of the UPC.

Section 504. Existing Food Service Establishments – NOT Upstream of "Hot Spot."

Existing FSEs that are not upstream of a sewer line hot spot do not have permit or GRD requirements under this Ordinance. However, owners and operators of such establishments should consider that if the FSE should discharge sufficient FOG to cause an obstruction in the



sanitary sewer, they would be in violation of Ordinance No. 112. Such discharge would also be likely to plug the FSEs drain lines, causing sewage back-ups into the kitchen.

Upon request, District personnel will provide FSEs with information regarding employee training and grease removal devices to minimize FOG discharge to the sewer.

ARTICLE VI. REQUIREMENTS FOR ALL FSEs SUBJECT TO THIS ORDINANCE. All new food service establishments (FSEs) and all existing FSEs upstream of a "sewer line hot spot" (hot spot) are subject to this Ordinance and shall have a current wastewater permit issued by the District and at least one grease removal device (GRD), as described in Article V of this Ordinance. The sole exception is any FSE granted a permit waiver, as discussed in Article VI, Section 601 below. All FSEs that are subject to this Ordinance shall comply with requirements Section 601 through 605 below, unless they are granted a permit waiver.

Section 601. Permit Waiver. All FSEs shall have a current wastewater permit issued by the District, unless the District grants a permit waiver. Waivers will be granted only to those FSEs that can demonstrate to the satisfaction of the District that they are not a significant source of FOG. This will normally be the case only if there is no cooking or clean-up taking place at the facility.

Section 602. Permit Fees. Section 5.D. of Ordinance No. 112 specifies that the District shall have the authority to assess and collect fees from users of the District system in order to recover costs as necessary and reasonable to demonstrate compliance with Ordinance No. 112 and/or a wastewater permit. The fees specified therein are applicable to FSEs as "Class III Users" of the system.

As discussed in Article VIII, Section 804 of this Ordinance, if an inspection by District staff determines that a permittee is in violation of one (1) or more requirements of this Ordinance, the permittee shall be assessed a fee to reimburse the District for the cost of a re-inspection to determine that the violation has been corrected. Additional fees may be assessed if a District compliance order is issued to the permittee, as discussed in Article VIII, Section 805 of this Ordinance. All such fees are in accordance with Section 5.D. of Ordinance No. 112.

All fees associated with violations of the wastewater permit, as discussed in the preceding paragraph, shall be in addition to any uniform fee assessed by the District on permittees in order to recover the cost of the FOG control program established by this Ordinance.

As specified in Section 5.E. of Ordinance No. 112, all fees assessed by the District pursuant to Section 5.D. are due and payable upon receipt of such notice. Section 5.E. specifies District procedures regarding fees not paid in a timely manner.

Section 603. Grease Recycling Bin. All FSEs shall have a bin or drum for collecting waste kitchen grease and used cooking oil. FOG cleaned out of grease traps shall not be placed in this container, as it is more difficult to recycle. The container shall be used and maintained adequately to prevent spillage or leakage.

The container shall be serviced (emptied or exchanged) and recycled in a legal manner at an appropriate frequency. Receipts or other documentation of such service shall be retained at the FSE and presented to District staff on request. The FSE shall maintain adequate employee training and/or kitchen signage to assure that the container is used and maintained in an appropriate manner.

Section 604. No Storm Water Pollution. All FSEs shall operate so as to prevent any discharge of FOG or other wastes to storm water drainage in violation of Ordinance No. 1672 of the City of San Rafael (Storm Water Management and Discharge Control Program Ordinance) or, if outside the City of San Rafael, the Storm Water Ordinance of the County of Marin. Serious or repeated discharges to storm drainage from an FSE will be referred to the appropriate authorities for enforcement action.

Section 605. GRD Additives Prohibited. Addition of enzymes, solvents, or emulsifiers to GRDs (grease traps or interceptors) or to drains leading to these devices is prohibited.

Section 606. Food Grinders Prohibited. A food grinder (garbage disposal) shall not discharge to a grease removal device (grease trap or grease interceptor).

ARTICLE VII. MAINTENANCE REQUIREMENTS FOR GRDs. The wastewater permit issued to an FSE will specify the required minimum frequency for maintaining (pumping or hand cleaning) the grease removal device(s) and how the FSE shall verify this maintenance. The options are described below:

Section 701. Grease Interceptors and Large Grease Traps. For an FSE with a grease interceptor or a grease trap larger than thirty (30) gallons liquid capacity (35 gpm rating / 70-pound grease storage capacity), the interceptor or trap shall be pumped (i.e., all compartments pumped empty) and the contents legally disposed at a minimum frequency of once every three (3) months. The District may require more frequent pumping if inspections by District staff indicate that pumping every three (3) months is not adequate. At the discretion of the District,

the required frequency may be reduced if the FSE provides documentation (e.g., hauler certifications) adequate to establish that less frequent pumping would suffice. Such documentation shall be based on a minimum of one (1) year of quarterly pumping and shall be verified by District inspections.

All pumping shall be performed by persons who are certified by the California Department of Food and Agriculture (DFA) as a “registered transporter of inedible kitchen grease.” The pumper shall transport the pumped waste to an “authorized receiving facility,” as defined by the DFA. DFA regulations require the pumper to provide the FSE with a “waste removal receipt,” which includes the name of the FSE, the date of the pumping, the “working capacity” of the interceptor pumped (see Article IV of this Ordinance) and the total gallons pumped.

The District will provide the FSE with a file pouch and a supply of self-addressed envelopes. Within one (1) week of each pumping, the FSE shall mail a copy of the waste removal receipt to the District, using one of the supplied envelopes. The FSE shall file another copy of the receipt in the file pouch, for presentation to District staff on request. Receipt copies shall be retained in the pouch for a minimum of three (3) years.

Section 702. Grease Traps. FSEs with a grease trap of thirty (30) gallons liquid capacity (35 gpm rating / 70-pound grease storage capacity) or less may choose to comply with the procedure specified in Article VII, Section 701 of this Ordinance, except that the minimum pumping frequency shall be monthly, unless modified in the permit, as described above.

All FSEs with a grease trap of thirty (30) gallons liquid capacity (35 gpm rating / 70-pound grease storage capacity) or less who do not choose to comply with the above shall comply with the procedure specified below:

- The grease trap shall be cleaned by FSE staff and/or a contractor, at a minimum frequency of once every fifteen (15) days. The District may require more frequent cleaning if inspections by District staff indicate that cleaning every fifteen (15) days is not adequate. At the discretion of the District, the required frequency may be reduced if the FSE provides documentation (e.g., logbook observations) adequate to establish that less frequent cleaning would suffice. Such documentation shall be based on a minimum of six (6) months cleaning at a minimum fifteen (15) day frequency and shall be verified by District inspections.
- Persons cleaning a trap shall assure that all grease and sediment is removed and appropriately disposed. They shall also assure that all baffles, flow-control

devices, and other equipment are properly installed subsequent to the cleaning. All wastes removed from the trap during cleaning shall be placed in a drum or other dedicated container and be removed by a “registered transporter of inedible kitchen grease,” as described in Article VII, Section 701 of this Ordinance. The trap waste may not be placed in the “grease recycling bin” specified in Article VII, Section 603 of this Ordinance, unless the grease hauler provides written certification that this is acceptable and the hauler complies with all DFA regulations for “inedible kitchen grease.”

- Cleaning of a trap shall be documented on a log sheet maintained by the FSE. The log sheet shall include, at a minimum, the date of the cleaning event, the name of the person(s) performing the cleaning, their signature, the quantity of waste removed from the trap, and any other relevant observations. The completed log sheets shall be maintained on site in a file pouch supplied by the District for a minimum of three (3) years and provided to District staff on request. The FSE shall provide to the District (mail or fax) a copy of their current log sheet at a frequency specified by the District in the FSE permit.

ARTICLE VIII. DISTRICT MONITORING OF PERMIT COMPLIANCE. District staff will monitor FSE compliance with this Ordinance and the wastewater permit. Below is an outline of the routine monitoring and enforcement procedures. The District reserves the right to modify these procedures, as appropriate.

Section 801. Permits. As specified in Article VI and Article VI, Section 601 of this Ordinance, all new FSEs and FSEs upstream of a sewer line hot spot shall have a District wastewater permit or a permit waiver. District staff shall not issue a permit until they have verified that the FSE is in compliance with the grease removal device (GRD) requirements specified in Article V of this Ordinance. If an FSE has an existing GRD that must be replaced due to inadequate sizing, an interim permit may be issued to specify maintenance of the existing GRD.

The permit issued to an FSE shall specify the required maintenance (pumping or cleaning) frequency for the GRD and the requirements for verifying maintenance in accordance with Article VII of this Ordinance.

Section 802. Permit Inspections. Sections 4.A.2.g., 4.A.2.i., and 7.A. of District Ordinance No. 112 give District staff authority to perform inspections on the premises of sewer

users and to review user records relevant to sewer discharge.

District staff will perform on-site inspections of FSEs to verify compliance with the permit. The inspections will normally be unannounced. District staff will attempt to schedule inspections so as to minimize the impact on the operation of the FSE (e.g., no visiting during the lunch period). However, the FSE shall provide District staff, at all times that the FSE is open and/or in operation, with access to the FSE in order to inspect the premises, GRDs, and maintenance records. This specifically includes access to the grease removal device. If the device is inaccessible to District staff due to placement of vehicles, mats, utensils, etc., FSE staff shall remove such obstacles in a timely fashion. If District staff must re-visit an FSE in order to complete an inspection as a result of adequate access not being provided, a re-inspection fee, as discussed in Article VIII, Section 804 below, shall be assessed. The reinspection fee will not be assessed only in those cases where the District inspector documents adequate extenuating circumstances.

Section 803. Permit Violations. The following conditions are violations of an FSE wastewater permit and shall normally result in issuance of a Notice of Violation (NOV), in accordance with Section 10.A.1. of Ordinance No. 112. At the discretion of District staff, a verbal warning may be given instead of an NOV for “borderline” violations or where there are extenuating circumstances. Egregious and/or repeated violations may result in escalated enforcement action, as described in Article VIII, Section 805 below. An NOV shall state the violation(s), the corrective action(s) required, and the date the corrective action(s) must be completed.

- (a) GRD not maintained. The permit shall specify the minimum maintenance frequency required in accordance with Article VII of this Ordinance. If documentation of adequate maintenance is not provided to District staff, the FSE shall be in violation. Regardless of the frequency of maintenance, any GRD with a combined level of floating FOG and settled solids in any compartment which exceeds twenty-five (25) percent of the liquid depth of that compartment shall be considered to be in violation.
- (b) GRD not in working condition. All vents, baffles, inlet and outlet devices and flow-control devices necessary for proper operation of the GRD and compliance with this Ordinance must be in place and in working condition at all times.
- (c) Grease recycling bin not in use. Unless exempted in the permit, the FSE shall comply with Article VI, Section 603 of this Ordinance.

- (d) Prohibited compounds discharged to GRD. Unless specific compounds are authorized in the permit, the FSE shall comply with Article VI, Section 605 of this Ordinance.
- (e) FOG discharged to drain not connected to GRD. See Article V, Section 502 and Article V, Section 503 of this Ordinance. Repeated incidents may result in requirement to connect the drain to a GRD.
- (f) Access denied to District staff - See Article V, Section 802 above.

Section 804. Re-Inspection. If a Notice of Violation (NOV) is issued for violation of an FSE wastewater permit, the FSE shall be assessed an inspection fee, in accordance with Section 5.D.2. of Ordinance No. 112. The fee shall reimburse the District for the cost of inspecting the FSE to verify the corrective action required by the NOV.

Normally, the re-inspection fee shall be a standard charge equal to 1.5 times the weighted hourly salary for the District staff normally performing FSE inspections, plus sixty (60) percent overhead. In exceptional cases, requiring substantially more than 1.5 hours staff time for all follow-up to the NOV, the re-inspection fee shall be based on actual staff time documented.

Section 805. Escalated Enforcement. Where deemed necessary to achieve compliance with this Ordinance, the District will take escalated enforcement action beyond or in addition to the Notice of Violation. The normal intermediate enforcement action is an Administrative Order, as described in Section 10.A.3. of Ordinance No. 112. Fees may be assessed as part of an Administrative Order in order to recover District costs for the enforcement action.

ARTICLE IX. HEARINGS AND APPEALS. Section 11. of LGVSD Ordinance No. 112 is hereby incorporated by reference into this FOG Ordinance (No. XXXX). Any person wishing to appeal a decision, action, or determination of the District pursuant to this FOG Ordinance shall comply with all relevant provisions of Section 11 of Ordinance No. 112.

ARTICLE X. SEVERABILITY. If any provision, paragraph, word, section, or article of this Ordinance is invalidated by any court of competent jurisdiction, the remaining provisions, words, sections, and chapters shall not be affected and shall continue in full force and effect.

ARTICLE XI. REVISION. The Sanitary Board of the Las Gallinas Valley Sanitary District reserves the right to update, change, or modify this Ordinance when deemed advisable and necessary.

APPENDIX A

Grease Removal Device Requirements for Food Service Establishments (FSEs)

	NOT Upstream of "Hot Spot"	Upstream of "Hot Spot"
New FSE	Interceptor* required (see V.501 – Page 4)	Interceptor* required (see V.501 – Page 4)
Major remodel	Grease trap required (see V.502 – Page 4)	Interceptor required*** (see V.502 – Page 4)
Existing FSE	No requirement (see V.504 – Page 7)	Grease trap required*** (see V.503 – Page 5)

\* Interceptor = Outside, 750 gallons minimum, connected to all kitchen drains

\*\* For remodels interceptor may not need to be connected to all kitchen drains, at the discretion of the District.

\*\*\* “Conditional Permit” for grease trap installations (existing traps or newly installed in existing restaurants) can be revoked if "hot spot" conditions do not subside. The FSE would then have to install an interceptor, as for a major remodel.

This page intentionally blank



## CHAPTER 5

### AN ORDINANCE PROHIBITING FOOD GRINDERS IN COMMERCIAL FOOD SERVICE ESTABLISHMENTS.

#### SECTION 1. Purpose.

The Las Gallinas Valley Sanitary District (District) is adopting an Ordinance (FOG Ordinance) to control the discharge of fats, oils, and grease (FOG) to the sanitary sewers from food service establishments; and

The FOG Ordinance requires restaurants and other food service establishments in the District service area to have a grease removal device (grease trap or grease interceptor) in use. The purpose of this device is to remove FOG from kitchen drainage before it is discharged to the sanitary sewer; and “Food grinders,” also known as “garbage disposals,” are devices installed in kitchen plumbing for the purpose of grinding food waste or food preparation by products for the purpose of disposing into the sanitary sewer system; and

The installation of a food grinder such that it discharges to a grease removal device will, in most cases, render the device less effective or unable to perform its function; and

The ground food discharged by food grinders is a significant source of FOG which could harden in the sanitary sewer; and

Food grinders are not essential to kitchen operation. Their function can be readily replaced by having kitchen personnel scrape food wastes into solid waste receptacles.

#### SECTION 2. Prohibition Against Installation of Food Grinders.

Installation of food grinders in new or remodeled commercial food service establishments is prohibited. Food grinders shall removed front existing commercial food service establishments within 180 days of the adoption of this ordinance.

## **From LGVSD Ordinance Code, Chapter 2, Article IV (General Prohibitions)**

ARTICLE IV. STANDARDS AND LIMITATIONS. The District has set forth the following prohibitions and limitations for waste discharge to the system. Where National Categorical Standards are applicable, the discharger must comply with the more stringent of the District local limit or the applicable categorical standard for a given pollutant.

Section 401. General Discharge Prohibitions. No person shall contribute to or cause to be contributed to the system any waste or any pollutant which will:

- (a) Cause interference with the system.
- (b) Damage the system.
- (c) Cause pass-through of the system.
- (d) Cause hazard to the public safety, the environment, or to District personnel.

Section 402. Specific Prohibitions. No person shall discharge any waste to the system, except through sewer connections approved by the District. Discharge at any other location, specifically including collection system manholes, is prohibited without prior written approval from the District.

Except as hereinafter provided, no person shall discharge, or cause to be discharged, to the system any of the following described waters or wastes:

- (a) Any solid or viscous pollutants in amounts which will cause obstruction to the flow in the system or which will require unusual attention or expense to convey and/or treat. In no case shall there be discharge of any solid material not capable of passing through a three-eighths (3/8) inch mesh screen.
- (b) Pollutants which create a fire or explosive hazard in the system, including, but not limited to, waste streams with a closed-cup flashpoint of less than 140°F (60°C) using the test methods specified in 40 CFR 261.21.
- (c) Heated discharges in amounts which will inhibit biological activity in the treatment facility resulting in interference. Heated discharges in such quantities that the temperature at the treatment plant exceeds 104°F (40°C) or which pose a hazard to District personnel.
- (d) Any discharge which has been diluted as a partial or complete substitute for treatment to achieve compliance with this Ordinance, the

user's waste discharge permit, or the National Categorical Standards.

- (e) Any discharge of hazardous waste, as defined by Title 22 of the California Code of Regulations, without the written approval of the District.
- (f) Any discharge which causes noxious or malodorous gases at or near the District's facilities or which otherwise creates a public nuisance.
- (g) Pollutants which result in the presence of toxic gases, fumes, or vapors within the District's facilities in a quantity that endangers the health or safety of District's personnel.
- (h) Any storm water, surface water, groundwater, roof runoff or subsurface drainage, except in cases of discharge of contaminated groundwater in accordance with Article IX.
- (i) Any radioactive wastes, except as allowed under the "California Radiation Control Regulations," CCR Title 23 Section 30100 et seq.
- (j) Any discharge of any pollutant, including oxygen-demanding pollutants (BOD, etc.), released at a flow rate and/or concentration which will cause interference with the system.
- (k) Any discharge containing petroleum oil, nonbiodegradable cutting oil, or products of mineral oil origin in amounts that, alone or in conjunction with other discharges, will cause interference or pass-through.
- (l) Any discharge which, alone or in conjunction with a discharge or discharges from other sources, will compromise the use of District's treated wastewater for any adopted reclamation use.
- (m) Pollutants which will cause corrosive structural damage to the system.
- (n) Substances containing greater than five (5) percent copper by weight, added to control roots or for any other purpose.

This page intentionally blank

## LGVSD FOG Facilities ("Hot Spot") List

FSE Name	Address	FSE Status
AlmaVia Of San Rafael	515 Northgate Drive	Re-plumb Review
Applebees	3050 Northgate Mall	Permit- Pumped
BJ's Restaurant	5800 Northgate Dr.	Permit- Pumped
Black Bear Diner	490 Las Gallinas Ave	Permit- Pumped
Calgang	194 Northgate One	Permit- Pumped
Chipotle	194 Northgate One	Permit- Pumped
Dandy Market Deli	100 El Prado Ave # 1	New/ Remodel
Eduardo's	4200 Redwood Hw	Permit- PENDING
Embassy Suite / Rings	101 McGinnis Pkwy	Permit- Pumped
FICO cafeteria	200 Smith Ranch Road	Closed
Flannery Beef	139 Carlos Dr	Permit- Selfclean
Gasperes Pizzeria	200 Merrydale Rd	Permit- Selfclean
Guide Dogs for the Blind	50 Los Ranchitos Rd	Permit- Pumped
Happy Garden	4166 Redwood Hwy	Closed
High Tech Burrito	484 Las Gallinas Ave.	Closed
Ikoï Sushi	601 Del Ganado	New/ Remodel
Jelly Donut	244 Northgate One	Permit- Selfclean
Joe's Cafe	4150 Redwood Hwy	Permit- Selfclean
La Hacienda Taqueria	3815 Redwood Hwy	Permit- Selfclean
La Toscana Ristorante	3751 Redwood Hwy	Permit- Pumped
Marin School	150 North San Pedro Road	Permit- Pumped
Marinwood Market	155 Marinwood Ave	Permit- Pumped
McDonalds	190 Merrydale Rd	Permit- Pumped
McInnes Park Clubhouse	350 Smith Ranch Rd	Permit- Pumped
Mi Pueblo Marin	5800 Northgate Dr	New/ Remodel
Mulberry Street Pizza	101 Smith Ranch Rd	Permit- Pumped
Northgate Mall (In front of Panera)	5800 Northgate Mall	Permit- Pumped
Northgate Mall Food Court	5800 Northgate Mall	Permit- Pumped
Panda Express	5800 Northgate Mall	Permit- Pumped
Peking Wok	418 Las Gallinas Ave	Permit- Mixed
Pine Ridge Care Center	45 Professional Center Parkway	Permit- Pumped
Ping's	248 Northgate One	Permit- Pumped
Roast Haus	276 Northgate One	Permit- Pumped
Safeway	950 Las Gallinas	Permit- Pumped
Sakura Sushi	100 Smith Ranch Rd	Permit- Selfclean
Silbermann's Ice Cream	96 Northgate One	Permit- Selfclean
Smith Ranch Deli	101 Smith Ranch Rd	Permit- Pumped
Smith Ranch Homes	500 Deer valley Road	Permit- Pumped
Sonoma Taco Shop	210 Northgate One	Permit- Selfclean
Sonora Market Taqueria	649 Del Ganado Rd	Permit- Selfclean
Starbucks Coffee	260 Northgate One	Permit- Pumped
Stefano's Pizza	424 Las Gallinas Ave	New/ Remodel
Thai Kettle	621 Del Ganado	Permit- Selfclean
Three Martians Pizza	424 Las Gallinas Avenue	Closed
Tomatina	5800 northgate mall	Closed

This page intentionally blank

## LGVSF FOG Inspections: 2016-Current

FSE	FSE Status	Inspector Name	Inspection Type	Date	Contact Name	Contact Title	GRD Status	Comments	Compliance
Ping's	Permit- Pumped	Jose Gutierrez	Compliance	8/2/2018	Lee	Manager	Cleaned	This interceptor should be cleaned in a week according to the last grease pumping receipt. It looks like there is around 6" of FOG on the surface. Standpipes look good and tank effluent is free of grease. There is a problem as far as storage of their oil recycling. Sequential or Pure needs to swap out the oil bin that has oil all over it. And I let the manager know that he Pings is responsible for cleaning the area around the receptacle.	Verbal Warning
Mulberry Street Pizza	Permit- Pumped	Mary Jo Ramey	Dye Test	7/18/2018	Barbara Rowe	Owner	Cleaned	Dye Test on new 50 gpm GRD All DFUs connected as required. 1-comp, 2-comp and scrap sink. Mulberry St. Pizza is in the process of being sold and new owner will have to be permitted.	N/A not Permitted
Black Bear Diner	Permit- Pumped	Mary Jo Ramey	Pre-permit	5/8/2018	Fernando	Day Manager	Not Cleaned	Site Visit to open the interceptor and to meet the Manager and get the General Manager name to put on the FOG Permit. Met Fernando, the Day Manager and he informed me that a new General Manager was just assigned to San Rafael. His name is Thomas Smith.	N/A not Permitted
McInnes Park Clubhouse	Permit- Pumped	Jose Gutierrez	Compliance	5/4/2018	Eric Jensen	Food and Bev Director	Cleaned	This trap has 20-25 screws holding the lid and takes a lot of work to open. It looks like the month cleaning frequency is just right for this location. There was 2" of FOG on the surface but was to be cleaned in a week.	Compliant
Mi Pueblo Marin	New/ Remodel	Jose Gutierrez	Site Visit	5/4/2018	none yet		Not Cleaned	I dropped by the new location in the North gate mall. It looks like it is very close to opening. The restaurant looks to be all done and there is a sign looking to hire personnel. This restaurant took over the Tomatina location. The interceptor was ok but it might not have been left clean by the previous tenant.	N/A not Permitted
Thai Kettle	Permit- Selfclean	Jose Gutierrez	Compliance	5/4/2018	kim	manager	Cleaned	This GRD was not as expected. There was no cleaning log and the onsite employees did not know how long it was since the last cleaning. The speculated it had been over a few weeks. Mon the owner takes care of the cleanings during off hours. I will contact here give her more cleaning logs and also give her a warning for not up keeping the log.	Compliant
Sonora Market Taqueria	Permit- Selfclean	Jose Gutierrez	Compliance	5/4/2018	Gustavo	cook/partner	Cleaned	Has been using the log to capture cleanings. Especially after I gave him a verbal warning. There was 1/2" of FOG on surface and no solids on the bottom. Had been cleaned last week. There is lots of red oil	Compliant
Flannery Beef	Permit- Selfclean	Jose Gutierrez	Compliance	5/4/2018	Brian Flannery	owner	Cleaned	The GRD was cleaned earlier this week. There was very little FOG and solids. Looks good.	Compliant
Smith Ranch Deli	Permit- Pumped	Jose Gutierrez	Compliance	5/4/2018	Sean	owner	Cleaned	This grease trap is cleaned month about the same time. I opened the lid and inspected it a few days before its normal pumping. There was grease and oils in it but still in compliance. 1" FOG on surface and 1" of solids.	Compliant
Ping's	Permit- Pumped	Jose Gutierrez	Compliance	5/4/2018	Paul Chen	Owner	Cleaned	IWhen I arrived at the rear of the restaurant I could see that the backdoor space was very dirty and greasy. One of the issues I will email Paul about is the recycled oil container area. It looks dirty and there is lots of oil oozing around it. This need to be kept more tidy. Interceptor OK and in compliance	Compliant
Calgang	Permit- Pumped	Jose Gutierrez	Compliance	5/4/2018	Willie	manager	Cleaned	Opened interceptor lids and both compartments looked adequate. There was 2-3" of saturated FOG on surface but liquid underneath. Inlet was very greasy but outlet standpipe had clean water.	Compliant
Northgate Mall Food Court	Permit- Pumped	Jose Gutierrez	Compliance	5/4/2018	Ricardo	Mall Operations Manager	Cleaned	I opened the 2 manholes on this interceptor and found that the grease level was 3" on the surface. I could see that it was still clear in the standpipe leaving the interceptor. I attempted to open the sample box but could not manage to open this manhole. I'm guessing that the interceptor grease hauler does not service the sample box. I will speak with the ops manager to find out when the next cleaning is.	Compliant
BJ's Restaurant	Permit- Pumped	Jose Gutierrez	Compliance	5/4/2018	Vanessa	hostess	Cleaned	I opened the manhole to this grease interceptor and could see that it is getting serviced. It looks like it was getting closer to clean. There was roughly 2-3" of loose fog on the surface. I spoke with a hostess to verify if CHRIS the GM was still there. She let me know that Chris was no longer with BJ's this may be the reason for the lack of pump receipts forwarded to me. I will be emailing and calling the new GM to make contact and to explain what is needed to keep BJ's in compliance.	Compliant
Northgate Mall (In front of Panera)	Permit- Pumped	Jose Gutierrez	Compliance	5/4/2018			Cleaned	This is a large interceptor. the first manhole was stuck closed but I managed to open the 2nd. I found that there was very little FOG and solids in the interceptor. It appears that there was 2" of FOG and I could see that the effluent standpipe	Compliant
Marinwood Market	Permit- Pumped	Jose Gutierrez	Compliance	5/4/2018	none		Cleaned	Looks like the 2 compartments of the interceptor had been cleaned recently. There was .5" of FOG on the surface of the sample box. This area should be the clean effluent from the main compartment of the interceptor	Compliant
Panda Express	Permit- Pumped	Jose Gutierrez	Compliance	5/4/2018	none		Cleaned	Opened interceptor. 1.5" of FOG on surface. Clear in discharge standpipe and in sample box.	Compliant
Chipotle	Permit- Pumped	Jose Gutierrez	Compliance	5/4/2018	lynn	shift manager	Cleaned	Opened grease interceptor and was well maintained. There was only 2" of FOG on the surface.	Compliant
Ikoji Sushi	New/ Remodel	Jose Gutierrez	Pre-permit	5/4/2018	Leo	Owner	Cleaned	Opened GRD. Had not been to this location since they had installed. Grease system looks good and trap was cleaned. I let Leo know that I will be issuing a Permit and that his current pumping frequency looks good.	Compliant
Applebees	Permit- Pumped	Jose Gutierrez	Compliance	5/4/2018	Mario	cook	Not Opened	I looked around the sidewalk and the street for the interceptor lids. There was no sign of an interceptor. I asked a Mario if he knew where the haulers suck out the interceptor and he pointed me in the direction of a box on the wall with possible hook ups. I walked through the kitchen to see if perhaps there was only under sink GRD's but there was no additional traps. I came back to the office and found an old inspection that said the interceptor is in the parking lot. I will return to inspect.	Compliant
Roast Haus	Permit- Pumped	Mary Jo Ramey	Compliance	4/30/2018	Sam	Owner	Cleaned	500 gallon interceptor pumped on 4/9/18. I was confirming that the 2-comp, 3-comp, dishwasher drained to the interceptor. The mop sink did not go to the interceptor. The owner needed a letter to Marin County EHS stating the DFUs drained to the interceptor because he is selling to business.	Compliant
Happy Garden	Closed	Mary Jo Ramey	Site Visit	4/10/2018	Li Deyue (Derek)	Soon to be new owner	N / A	Site visit to Happy Garden Restaurant to check on install of hand sink in kitchen. Marin County EHS needed CMSA to write a WAIVER letter for the hand sink plumbing not going to the GRD. I met with the current owners whom are selling to a new owner at the end of May 2018.	Compliant
Stefano's Pizza	New/ Remodel	Mary Jo Ramey	Pre-permit	4/9/2018	Francisco	Manager	N / A	Site visit to new restaurant Stefano's Pizza moving into old location of Three Martians Pizza. Owner Bob Valentino called asking for an APPROVAL Letter from CMSA saying everything was okay with his restaurant. I told him that CMSA had never received restaurant plans for Stefano's Pizza. He informed me that he was not changing any plumbing and he just needed a letter saying everything was ok. I reviewed the history of Three Martians, and in 2012 the INSTALL Letter stated the 3-comp and 1-comp prep sink had to be connected to the GRD. But the Permit only had the 3-comp connected to the GRD. At the site visit, the 3-comp sink was connected to the GRD. The 1-comp prep sink was draining to a floor sink and the hand sink was a direct connect to the Sanitary Sewer. I informed Francisco that the 1-comp prep sink had to be connected to the GRD according to the FOG Ordinance. Bob Valentino called the office and asked about the 1-comp sink and why it had to be connected. He asked me to have my Supervisor Brian Thomas call him.	N/A not Permitted

FSE	FSE Status	Inspector Name	Inspection Type	Date	Contact Name	Contact Title	GRD Status	Comments	Compliance
Joe's Cafe	Permit- Selfclean	Mary Jo Ramey	Compliance	3/21/2018	George	Owner	Not Cleaned	George - Owner was at the receptionist station. He walked me back to the kitchen where we discovered that there were no current log sheets for cleaning. Kitchen manager was not in today. Walked over to the in-ground GRD Ashland 35gpm. Opened it and it had 3" of grease and solids on bottom. George had the busboy start to clean as I was writing my notes.	Compliant
Gasperes Pizzeria	Permit- Selfclean	Mary Jo Ramey	Compliance	3/21/2018	Oseas	Kitchen Prep	Not Cleaned	Gave Oseas more log sheets, they were out and had not been keeping track. Oseas opened the in-ground GRD and it was dirty and ready to be cleaned. He started to clean it and I reminded him to mark down the cleanings on the logsheet.	Compliant
Pine Ridge Care Center	Permit- Pumped	Mary Jo Ramey	Compliance	3/21/2018	Henry Brumley	Administrator	Cleaned	Met new Administrator for Pine Ridge Care Center, Mr. Henry Brumley. Currently there is no maintenance staff due to turnover in personnel. There is no front desk person who use to FAX pumping slips. Asked Mr. Brumley to send the monthly pumping receipts to my email or FAX. I met with kitchen staff - new kitchen manager. Opened the in-ground GRD under the DW for the scrap sink and the in-ground GRD connected to the 3-comp sink (other room). Both In Compliance even though no pumping receipts available.	Compliant
Jelly Donut	Permit- Selfclean	Mary Jo Ramey	Compliance	3/21/2018	Phoungoun	Owner	Cleaned	Opened Jelly Donut in-ground GRD located under sink. Took a picture and Phoungoun started to clean it, since it was slow and time to clean. Not alot of grease, waste familiar for bakeries.	Compliant
Black Bear Diner	Permit- Pumped	Mary Jo Ramey	Dye Test	10/26/2017	Karan Gogri	Property Manager	Not Cleaned	Flow Test on all DFUs and on EHS letter with JG. All sinks, mop sink, floor sinks and floor drains in kitchen prep area drained to 1000 gallon in ground interceptor. I mentioned to Karan Gogri - property manager that the interceptor ring was broken and might need to be replaced if the lid cannot be removed for cleaning.	Compliant
Peking Wok	Permit- Mixed	Jose Gutierrez	Site Visit	10/26/2017			Not Opened	I came to this location and saw that there was a grand opening banner hanging on the store front and in the parking lot. The owner was not at the location but I will email someone from county EHS to see if there has been an ownership change.	N/A not Permitted
High Tech Burrito	Closed	Jose Gutierrez	Site Visit	10/26/2017			Not Opened	I dropped by this restaurant because I saw the over head sign was down. I was going to inquire about what was going on. I saw that this restaurant has closed at this location and it is up for rent by the property manager. There was no one around to let me in but the building is somewhat cleared out. I will be changing the status of this restaurant to "Closed".	N/A not Permitted
Happy Garden	Closed	Jose Gutierrez	Site Visit	10/18/2017	Jia Haung	Owner	Not Cleaned	Looked at everything else that was plumbed into the outdoor grease trap. From what I can tell the outdoor trap is strictly for the wok sink. I also dropped off the GRD letter that is needed for the change of ownership. Happy Garden has one plumbing change to do before they are completely compliant with CMSA's FOG ordinance	Not Compliant
Happy Garden	Closed	Jose Gutierrez	Site Visit	10/13/2017	Jia Huang	owner	Not Cleaned	Inspected grease trap previous to change of ownership. GRD measures to be an estimated 35 gpm. The 2 comp pot washer and single sink in opposite room are connected but the 2 comp in the hallway and the dishwasher are not. The wok sink is connected solely to a second trap outside. I believe that they use the 2-comp as the duty sinks and they get used a lot. That could be the reason the inside grease trap sits and stays idle for long period of time causing some foul odors. I am having the owner connect the 2-comp prep sink indirectly to the grease trap via the floor sink.	Not Compliant
La Hacienda Taqueria	Permit- Selfclean	Jose Gutierrez	Compliance	9/1/2017	Jose	Owner	Not Cleaned	This location seems to always be impacted. There is lots of red oil and 2" of FOG on the surface. There is 1/2" of solids on the surface and according to the log it has been cleaned almost 2 weeks ago and looks like it will need attention soon.	Compliant
Thai Kettle	Permit- Selfclean	Jose Gutierrez	Compliance	8/31/2017	tangh	cook	Cleaned	Opened grease trap and it had 2" FOG 1/2" solids on bottom. I made sure that Thai kettle was pumping monthly. This is a new practice for them. I will be issuing a pumped permit for this location.	Compliant
Sonora Market Taqueria	Permit- Selfclean	Jose Gutierrez	Compliance	8/31/2017	Octavio Vilches	Cook / Partner	Cleaned	Trap was moderately greasy. There was 1-2" of FOG on surface and light on bottom. However Octavio let me know that he has forgotten to fill out the log. I gave him a verbal warning and let him know that not having an updated log was a violation and next time I would write an NOV.	Compliant
Smith Ranch Deli	Permit- Pumped	Jose Gutierrez	Compliance	8/31/2017	Sean	Owner	Cleaned	Trap is ready to be cleaned. Some red oil 2" FOG and 1" of solids on the bottom. I also reminded Sean to forward his cleaning receipts to me.	Compliant
Silbermann's Ice Cream	Permit- Selfclean	Jose Gutierrez	Compliance	8/31/2017	Curtis	Owner	Cleaned	The owner was going to clean after my visit. There was 1.5" of FOG in the trap but very little solids on the bottom. Before today it looks like it had been neglected for a month according to the log. Trap was Ok.	Compliant
Flannery Beef	Permit- Selfclean	Jose Gutierrez	Compliance	8/31/2017	Brian	Flannery	Cleaned	This trap is installed in the main butchering area. It does get some fatty tissue and some blood but doesn't generate lots of FOG. There was 1" of FOG on surface and some scraps on the bottom.	Compliant
Eduardo's	Permit- PENDING	Jose Gutierrez	Compliance	8/31/2017	Nuesa Lake		Not Opened	I spoke with Nuesa and her staff has been cleaning the trap manually, this month she will be switching to a pumped permit and will be having a company clean the trap for her. I let her know that there are many companies that do grease trap cleaning and that she should shop the service around. I will email Nuesa and confirm that she has contracted a pumper for monthly cleanings.	Compliant
Pine Ridge Care Center	Permit- Pumped	Mary Jo Ramey	Compliance	6/29/2017	Anthony	Maintenance Head	Cleaned	Inspected both GRDs in kitchen with Anthony. He could not find the pumping receipts, he is new to the job, as is the rest of the admin. staff at Pine Ridge Care Center. They just turned over management. He will email me the pumping receipts and he tried on Monday 7/3/17 but it did not work with my office iPhone.	Compliant
Joe's Cafe	Permit- Selfclean	Mary Jo Ramey	Compliance	6/29/2017	Francisco	Kitchen Manager	Cleaned	Opened GRD - .5 in. FOG very little solids. Cleaned couple of days ago Francisco said but no logsheet. I gave him more sheets and told him to make sure they log the dates cleaned.	Compliant
Jelly Donut	Permit- Selfclean	Mary Jo Ramey	Compliance	6/29/2017			Cleaned	Opened new in-ground GRD - you need a regular screwdriver because he has all the screws in the plastic lid. They are maintaining it well.	Compliant
Panda Express	Permit- Pumped	Gretchen Mueller-Plombo	NOV Follow Up	6/16/2017	Superior Plumbing		Cleaned	Went to location to check possible stand pipe issue. Upon inspection of all three compartments, I observed a fully functioning, recently pumped interceptor. I have no concerns of a broken stand pipe as stated in a recently issued NOV. It looks as though all prior damaged parts have been fully fixed and are in working order.	Compliant
Calgang	Permit- Pumped	Jose Gutierrez	Compliance	5/11/2017	Willie	Owner	Cleaned	This interceptor looks like it may have been cleaned recently. On of the compartments had not developed a FOG mat. Stand pipes look ok and water discharging is clear.	Compliant
Northgate Mall Food Court	Permit- Pumped	Jose Gutierrez	Compliance	5/11/2017	Scott	operations	Cleaned	I opened this interceptor while the new operations manager was meeting with the ops staff out front. We had long talk about expectations of the new regime at the mall. Ricardo will be my new point of contact and will be getting me the most recent pumping receipts.	Verbal Warning
Northgate Mall (In front of Panera)	Permit- Pumped	Jose Gutierrez	Compliance	5/11/2017	Scott	Operations	Cleaned	This is a larger interceptor and has a larger lid. The pic hole and one other compartments is very tough to grab with the tool. With the combination of the lid being stuck I could not open the middle section of the interceptor. I was able to look into the other sections and it looks like this interceptor is functioning correctly. There is a mat of FOG on the surface but the water leaving the interceptor is clear. It does look like it will be ready to pump in a few weeks. Mall has gone through a management change and I was able to meet the new Operations manager and will be receiving cleaning receipt regularly.	Compliant
Tomatina	Closed	Jose Gutierrez	Compliance	5/11/2017	Nanct	General Manager	Cleaned	inspected interceptor. Looks to be functioning correctly and is not yet overloaded. According to our records this restaurant should be pumped in the next couple weeks.	Compliant
BJ's Restaurant	Permit- Pumped	Jose Gutierrez	Compliance	5/11/2017	Chris	General Manager	Cleaned	This interceptor always seems heavy. BJ's is on a 60 day cycle and according to the pumping receipts will be do for a cleaning very soon.	Compliant



FSE	FSE Status	Inspector Name	Inspection Type	Date	Contact Name	Contact Title	GRD Status	Comments	Compliance
Chipotle	Permit- Pumped	Jose Gutierrez	Compliance	5/11/2017	Dakata	shift manager	Cleaned	This interceptor appears to have been cleaned regularly. It looks to have one more month. There is lots of FOG but last compartment stand pipe looks to be flowing clean. I took the new GM's business card and will be reestablishing contact to verify regular maintenance.	Compliant
Panda Express	Permit- Pumped	Jose Gutierrez	Compliance	5/11/2017	claudia Gomez	GM	Cleaned	This interceptor appears to have been cleaned recently. The final section of the interceptor had very little grease. There is a problem though the exit pipe seems to have lost its stand pipe. I will issue and NOV.	NOV Issued
La Hacienda Taqueria	Permit- Selfclean	Jose Gutierrez	Compliance	3/30/2017	Jose	owner	Cleaned	There was lots of red oil and 2" of FOG on the surface. There was also 1-2" of solids on the bottom. I spoke with dishwasher and asked him to open and clean every 2 weeks but it looks like 3 weeks was not enough.	Compliant
Thai Kettle	Permit- Selfclean	Jose Gutierrez	Compliance	3/30/2017	Mon	Owner	Not Opened	This is the second attempt to inspect during Business hours. I'm guessing that they only open on occasion and use this as a place to park they're catering truck. The outside area had lots of trash around I will try again next week.	Compliant
Sonora Market Taqueria	Permit- Selfclean	Jose Gutierrez	Compliance	3/30/2017	Octavio	cook/owner's husband	Cleaned	This GRD looks Ok. It looks like it could need a cleaning soon. The log sheets had not been updated. I had a talk with the owners and helped them understand what is expected on the logsheets. I expect the sheets to be up to date on their next inspection. 2" FOG on the Surface and 1" of solids on the bottom.	Compliant
McInnes Park Clubhouse	Permit- Pumped	Jose Gutierrez	Compliance	3/30/2017	Erick Jensen	food and Bev Director	Cleaned	Opened new GRD to make sure everything looks right. It is in working order. There was 1.5" of FOG on the surface and 5" of solids on the bottom. There was a couple screws missing in a location that is difficult to access with a tool so I'm guessing the pumper leaves them off.	Compliant
Jelly Donut	Permit- Selfclean	Mary Jo Ramey	Compliance	3/29/2017			Cleaned	Inspected Jelly Donuts and opened new GRD. Log sheets up to date and GRD is In Compliance.	Compliant
La Hacienda Taqueria	Permit- Selfclean	Jose Gutierrez	Compliance	12/30/2016	Jose	Manager	Not Cleaned	I told Jose that they must clean ASAP. There was lots of red oil and 2" of FOG on the surface and 1-1/2" on the bottom.	Compliant
Sakura Sushi	Permit- Selfclean	Jose Gutierrez	Compliance	12/30/2016	Mike	Owner	Cleaned	GRD was ok it had 1-1/2" of FOG on the surface and little solids on the bottom. It had been cleaned 2 weeks ago and might be ready sometime next week.	Compliant
Silbermann's Ice Cream	Permit- Selfclean	Jose Gutierrez	Compliance	12/30/2016		worker	Cleaned	GRD water level was lower than the outlet pipe. I double checked plumbing and verified the 3-comp was still connected. Perhaps the level was so low because the sink may not get used so often and the water evaporates over time.	Compliant
Flannery Beef	Permit- Selfclean	Jose Gutierrez	Compliance	12/30/2016	Brian	Owner	Not Cleaned	I told Brian to clean the trap ASAP. There was 2" of FOG on the surface but very little solids on the bottom. There was lots of solidified grease on the front baffle. I would think the draining was slowed by this obstruction. Brian has expanded his operation. Most of the building is now refrigerated and used during his peak season.	Compliant
Sonora Market Taqueria	Permit- Selfclean	Jose Gutierrez	Compliance	12/30/2016	Octavio	Cook	Not Opened	This restaurant has made some changes in its floor plan. They were closed through the new year and will reopen 1/3/17	Compliant
Thai Kettle	Permit- Selfclean	Jose Gutierrez	Compliance	12/30/2016	Mon	owner	Not Opened	Restaurant was shut down for the holidays. Will reopen January 3rd.	Compliant
Sonoma Taco Shop	Permit- Selfclean	Gretchen Mueller-Piombo	Compliance	11/10/2016			Cleaned	GRD is very clean and in compliance. The lid was a bit difficult to take off.	Compliant
Three Martians Pizza	Closed	Gretchen Mueller-Piombo	Compliance	11/10/2016			Cleaned	Cleaned recently and in compliance	Compliant
Happy Garden	Closed	Gretchen Mueller-Piombo	Compliance	11/8/2016			Cleaned	The inside GRD still has a very foul odor and color as it has in the past. Outside trap is clean and in compliance	Compliant
Black Bear Diner	Permit- Pumped	Mary Jo Ramey	Dye Test	11/8/2016	Karan	Property Manager	Cleaned	Dye tested all drain lines in Black Bear Diner which is in a state of remodel. Property owner was not there and he gave me the key code - 360 to get the key out of the box. JG confirmed flow at the interceptor as I placed a hose in the floor sinks and drains. I marked each floor sink/drain on my map I had drawn of the restaurant layout. 2 floor drains did not drain at all and I made note of them and will email Mr. Karan Gorgi about them tomorrow and attach the picture of them that I took. We rolled up our hose and locked the restaurant up - checking the door to confirm that it was secured. I texted Mr. Karan Gorgi that we had finished and locked the restaurant @ 03:30.	Compliant
Black Bear Diner	Permit- Pumped	Mary Jo Ramey	Site Visit	11/3/2016	Karan Gogri	Property Management	Cleaned	This restaurant is being remodeled and has a 2 manhole interceptor in the back of the parking lot. We opened both covers and it appears that the interceptor had been cleaned and will be clean enough to perform a dye test on the restaurant drain lines after they are cleaned by a plumber. We told Mr. Gogri they needed to be cleaned before we could perform a dye test because of all the demolition rubble and concrete dust in the floor sinks. I took pics and drew a site map of all floor sinks, and floor drains. We were told no plumbing changes only new fixtures replacing the old ones. Mr. Gogri will contact me when the drain lines have been checked and then we will set up a dye test date.	Not Compliant
Dandy Market Deli	New/ Remodel	Jose Gutierrez	Survey	10/11/2016			Not Opened	Inspected location to see what original equipment they may have had. It was a clean slate. They have no grease trap and with their remodel they will install a new trap and have no space restrictions	Compliant
Eduardo's	Permit- PENDING	Jose Gutierrez	Pre-permit	9/2/2016	Nuesa lake	Owner	Cleaned	Install is a bit of an obstruction but they were able to put in a 35 gpm grease trap. They are ready to permit.	Compliant
Marin School	Permit- Pumped	Jose Gutierrez	Pre-permit	9/2/2016		Head Chef	Cleaned	A simple flow test was done to ensure the sinks were connected to the grease trap. Installation was done correctly, pictures taken. Will issue Permit	Compliant
McInnes Park Clubhouse	Permit- Pumped	Jose Gutierrez	Compliance	8/26/2016	Nancy	Soux chef	Cleaned	Opened trap looked ok. In ground GRD was functional and had only 1" of FOG on surface. Mechanical GRD was looking to be disconnected for servicing. Thick in trap needs to be cleaned and put back in service	Compliant
AlmaVia Of San Rafael	Re-plumb Review	Jose Gutierrez	Dye Test	8/23/2016	Brian Zimmerman	Facilities Director	Cleaned	Interceptor was recently cleaned and we were able to dye test successfully. 3-comp, 2-comp and tough other floor sinks are connected. The trough/scrub sink was not connected neither was the mop sink or any floor drains.	Not Compliant
Jelly Donut	Permit- Selfclean	Mary Jo Ramey	Replumb	8/9/2016	Phoungoun -	Owner	Cleaned	Confirmed new in-ground Ashland PolyTrap 35gpm installed. Verified 2-comp sink drains to GRD.	Compliant
FICO cafeteria	Closed	Jose Gutierrez	Pre-permit	8/3/2016	Ron Lake	Facilities Director	Cleaned	Both new grease trap installations were done very well. This meets CMSA requirements. They will be pumping and sending in the pump receipts.	Compliant
Iko Sushi	New/ Remodel	Jose Gutierrez	Survey	7/21/2016		Owner	Not Opened	Grd installed but trenches were still open and floor sinks not install yet.	Not Compliant
Peking Wok	Permit- Mixed	Jose Gutierrez	Compliance	4/21/2016			Cleaned	I opened all 3 grease traps. There is one at the 3 comp, one at the prep sink and 1 in ground from the Wok stove. It appeared that this trap did not have a baffle but it is an old style trap with the effluent channel is on the bottom and you cant see the discharge. I let the manager know about my findings.	Compliant
Peking Wok	Permit- Mixed	Jose Gutierrez	Compliance	11/20/2015			Cleaned	All grease traps were very congested with grease. According to the manager they should be pumped soon. They are all smaller than the 35gpm according to estimated measurements there are no identifying sizing tags. I have given the manager my card and email address to establish better communication to make sure we get all the pump receipts.	Compliant

This page intentionally blank

**BOARD OF DIRECTORS OF THE  
LAS GALLINAS VALLEY SANITARY DISTRICT**

**ORDINANCE NO. 153**

**AN ORDINANCE ADDING TITLE 2, CHAPTER 8, TO THE ORDINANCE CODE OF  
THE LAS GALLINAS VALLEY SANITARY DISTRICT, AUTHORIZING  
CONTRACTUAL ASSESSMENT BETWEEN THE DISTRICT AND PRIVATE  
PROPERTY OWNERS TO ADD THE COSTS OF REPAIRS OF SEWER LATERALS TO  
THE PROPERTY TAX ROLL FOR EACH INDIVIDUAL PROPERTY FOR WHICH  
THE CURRENT PROPERTY OWNER ENTERS INTO A CONTRACTUAL  
ASSESSMENT AGREEMENT WITH THE DISTRICT.**

NOW, THEREFORE, The Board of Directors of the Las Gallinas Valley Sanitary District, Marin County, California, hereby does ordain as follows:

Section 1. TITLE 2, CHAPTER 8, IS HEREBY ADDED TO THE ORDINANCE CODE OF THE LAS GALLINAS VALLEY SANITARY DISTRICT, to read as follows:

ARTICLE 1. FINDINGS & DETERMINATIONS:

Section 101. The Las Gallinas Valley Sanitary District (“District”) finds and determines that Infiltration and Inflow (“I&I”) is a serious problem for the District in that during heavy rains a significant amount of water is introduced into the District’s system as a result of I&I from breaches in the entire pipeline system that leads to the District’s sanitary treatment facility. To a great extent much of this I&I is introduced into the District’s pipelines and sewer mains from the sewer laterals leading from a property to the District’s sewers mains. As a result of I&I the District’s sewer treatment facilities have and will become overburdened during periods of heavy rains leading to sewage overflows, ground water contamination and spills into the waters of San Pablo Bay. Such overflows and spills can lead not only to significant fines and penalties against the District by State and Federal water regulatory agencies, but poses a significant risk to the environment, and the health and safety of the public at large.

Section 102. In the of interest addressing the I&I problem, the District has undertaken a Sewer Repair Program and has replaced portions of the existing sewer mains located within its jurisdiction and has an ongoing rehabilitation program. In addition, the District has studied numerous private sewer laterals and has found a significant portion of them are of such an age that a significant amount of I&I from rainwater occurs during heavy rains. Furthermore, most private property owners are unaware of the condition of their sewer laterals unless there has been a need for a repair.

Section 103. The District has determined that it is in the public interest that the private sewer laterals I&I problem be addressed and that it become the policy of the District that the upgrade and repair of private sewer laterals become a priority of the District. Therefore, with such a policy in mind District staff has developed a program for the repair and upgrade of private sewer laterals in conjunction with the District’s program of sewer main rehabilitation.

Section 104. As part of the overall Sewer Rehabilitation Plan the District has allocated “Contractual Assessment Funds” from its budget. It is the intention of the District to have these Contractual Assessment Funds available to front the costs of private sewer lateral repairs and rehabilitation, and thereby act as an incentive to private property owners to repair and upgrade their sewer laterals where needed. However, the implementation of this program had been delayed due to the lack of legislation allowing the District to move forward with such an incentive plan.

Section 105. Recent legislation by the California Legislature (AB 741) has amended various sections of the Health and Safety Code thereby allowing public entities to enter into Contractual Assessment agreements with private property owners under which the costs of repairs to an owner’s laterals can be financed and collected by use of the local county tax rolls. Under this statutory authority the District can pay for the costs of repairs to an owner’s sewer laterals and then, by agreement with the property owner, add the costs of such repairs to the County Tax Rolls as an assessment.

#### ARTICLE 2. PRIVATE SEWER LATERAL REHABILITATION PROGRAM:

Section 201. Beginning on January 1, 2012, and each fiscal year, thereafter, beginning July 1, 2012, the District shall make available a set amount of Contractual Assessment Funds for use by the District to conduct repairs on private property owners sewer laterals. The Contractual Assessment Funds available for such use shall be set by the Board. These Contractual Assessment Funds shall be first made available to those property owners whose property(ies) are affected by the current year’s Sewer Improvement Project. If there are Contractual Assessment Funds remaining, then those Contractual Assessment Funds may be used for sewer lateral repairs that are not part of the current Sewer Improvement Project.

Section 202. Criteria for participation in the Private Sewer Lateral Rehabilitation Program:

- a. Property Owners must submit an application (and any additional documentation required by the District) for inclusion in the Private Sewer Lateral Rehabilitation Program. All applications and documents must be completed, received and approved by the District before any work may commence. A “Contractual Assessment Agreement” (a copy of which is attached hereto as Exhibit “A”) shall be executed and submitted to the District and approved by the District.
- b. Sewer laterals in the worst condition shall be given priority.
- c. Property owners must have a video inspection of their sewer laterals and have the laterals rated under the Pipeline Assessment Certification Program (PACP) guidelines.
- d. The sewer lateral must have least one (1) PACP rated defect.
- e. The property shall not be encumbered with delinquent property taxes, special assessments or other assessment loans. If delinquencies exist, the property owner must provide documents of special payment arrangements to eliminate the delinquency, and related payment histories.

Section 203. Criteria for participation in the Private Sewer Lateral Rehabilitation Program for property owners whose property(ies) are not part of the current year's Sewer Improvement Project.

- a. Applications will be taken on a first-come, first-served basis.
- b. A video inspection of the sewer lateral may be observed by District personnel.
- c. The property owner must obtain three (3) quotes from a licensed contractor. If the owner is a licensed contractor or plumber they may elect to complete the work themselves and finance the costs of materials and equipment.
  - 1) District has the discretion to provide Contractual Assessment Funds in an amount not to exceed either a) the lowest of the qualified bids submitted to the District by the property owner, or b) the actual cost of construction of the work performed, whichever is less.
- d. All applications and documents must be completed, received and approved by the District before any work may commence.
- e. The property owner is responsible for managing the work, including the activities of the contractor, District permitting and inspection, restoration work, repairs and claims for damages incurred. The property owner shall retain all receipts, permits, inspection reports and other documents.
- f. The District may authorize payment once the property owner has presented documentation, including all necessary permits and inspections, an itemized statement of costs, and Conditional Release executed by the contractor, and a Notice of Completion, executed by the property owner, accepting the improvements and authorizing payment. A "Contractual Assessment Agreement" (a copy of which is attached hereto as Exhibit "A") shall be executed and submitted to the District and approved by the District prior to payment. The District will pay the contractor directly for the work performed.
- g. For any extra work, the property owner may present a written request for additional Contractual Assessment Funds for said extra work. However, the District shall have sole discretion to approve/disapprove any additional Contractual Assessment Funds for any extra work. The contractor shall not be paid any additional Contractual Assessment Funds for extra work, unless a written change order or extra work order is executed by the property owner, contractor and the District prior to the extra work being commenced.

Section 204. Late Applications/Administrative Relief: In the event that a property owner fails to timely submit an application for inclusion or participation in the Private Sewer Lateral Rehabilitation Program, as outlined above in Sections 202 and 203, the property owner may seek administrative relief from the District to be allowed to submit a "Late Application."

The granting of relief by the District to allow a property owner leave to file a "Late Application" shall not be construed to guarantee, represent or warranty that a property owner will be allowed to participate in the Private Sewer Lateral Rehabilitation Program. It is solely within the District's discretion whether to allow a property owner to participate in the Program. Any

the District's discretion whether to allow a property owner to participate in the Program. Any work performed that is sought to be included in the Private Sewer Lateral Rehabilitation Program pursuant to the submission of a "Late Application" is at the owner's risk and cost.

In no case may a "Late Application" be filed with the District greater than ninety (90) days from the substantial completion of the work or after a Notice of Completion has been recorded, whichever is earlier. "Late Applications" filed after ninety (90) days shall be rejected and are not subject to further request for relief or appeal.

Section 205. All work must be completed prior to the end of the District's fiscal year to be eligible for payment by the District. Contractual Assessment Funds will be obligated for a period not to exceed Ninety (90) days from approval. The obligation period shall include all work, inspections, and submission of receipts for payment.

Section 206. A permit is required from the District and a final inspection by the District. No fee shall be charged to the property owner for the permit or the final inspection.

Section 207. Contractual Assessment Principle and Interest Rate:

- a. The principal sum of cost of repairs to each property owner's sewer lateral shall constitute a lien against Owner(s) property, not unlike that of a regular assessment against said property for the District's regular annual assessment for sewer charges related to sewer service for purposes of collection of said principal sum and interest.
- b. Said principle sum to accrue interest at the rate of two percent (2%) per annum.
- c. The maximum amount of the initial Contractual Assessment Principle allowed per property shall be \$10,000.
- d. The term of each Contractual Assessment shall be ten (10) years.
- e. There shall be no prepayment penalty. Nor shall the payment schedule be accelerated upon the sale or transfer of the property.

Section. 208. Each property owner shall be responsible for any additional fees or charges, to include but not limited to title search fees and recording fees, related to the preparation, execution and/or recording of the Contractual Assessment Agreement. These fees may be added to the principal amount of the lien against the property which is to be added to the County Tax Rolls at the District's discretion.

Section 209. Pursuant to Health & Safety Code §§ 5470 – 5474.10 and 6940 – 6941.9, Owners(s) and the District shall enter into a "Contractual Assessment Agreement" whereby it is agreed that the above-referenced semi-annual principal and interest installment amounts shall be collected pursuant to the procedures for regular lien(s)/assessment(s) by addition of said installment payments to the County of Marin Tax Rolls, to be collected at the same time and in the same manner as county taxes are collected.

Section 210. Said lien/assessment shall be of the same force and effect as other liens for taxes, and their collection shall be enforced by the same means as provided for the enforcement for liens for county taxes.

Section 211. The "Contractual Assessment Agreement" executed by each Property Owner and approved by the District shall be recorded with the Marin County Recorder's office. A copy shall also be provided to the Marin Tax Collector if necessary.

Section 212. Pursuant to Health & Safety Code Section 6487 the District's General Manager or designee is hereby authorized, on behalf of and in the name of the District, to execute each "Contractual Assessment Agreement" entered into with a Property Owner.

ARTICLE 3. DESIGN, CONSTRUCTION AND MAINTENANCE OF SEWER  
LATERALS:

Section 301. Unless specifically stated herein, the design, construction and maintenance of a sewer lateral are governed by "The Ordinance Code of the Las Gallinas Valley Sanitary District" ("the Code"), and more specifically, but not limited to, Title 2 Chapter 1, "The Sanitary Code of Las Gallinas Valley Sanitary District of Marin County" and, Title 2 Chapter 3, "Regulating the Construction and Installation of Sanitary Sewer Facilities in Areas Underlain By Bay Mud."

Section 302. The work done on the lateral sewers shall not grant the District, its agents, employees and/or contractors the power to exercise dominion or control over the subject property, and shall not be construed as creating a public project or substantial participation in the planning, approval, construction or operation of the lateral sewers for any purposes. The work does not constitute a grant of any permanent real property rights to the District. Nor is the District's participation in this program to be construed as an acceptance of any permanent real property rights or obligations without express approval of the District's Board and conveyance by a separate written instrument executed by the appropriate party(ies).

Section. 303. The Owner of the lateral sewers shall be solely responsible for all future maintenance and repairs to the sewer lateral or everything required to install and maintain said laterals, including cleanouts or any wyes or tees attached or "cut-in" to the main sewer lines. Any warranty(ies) provided for materials supplied or work performed shall remain with the property owner and it shall be the property owner's responsibility to maintain and/or make any claims thereunder.

Section 2. FURTHERMORE, SECTION 513, IS HEREBY ADDED TO TITLE 2, CHAPTER 1, OF THE ORDINANCE CODE OF THE LAS GALLINAS VALLEY SANITARY DISTRICT, to read as follows:

"Section 513. Alignment of Existing Sewer Laterals. The District may require a property owner to relocate or realign the path or run of an existing sewer laterals as is necessary to avoid utilities, buildings, structures, vegetation or trees, or other physical impediments or obstacles, and/or the addition of additional clean-outs in order to ensure access to said sewer lateral for inspection, repair and/or maintenance."

Section 3. Upon adoption of this Ordinance, it shall be entered in full in the minutes of the Board of Directors of Las Gallinas Valley Sanitary District, shall be posted in the District, and shall be published once in the Marin Independent Journal. It shall be effective seven (7) days after publication.

Section 4. All other ordinances and parts of ordinances inconsistent herewith are hereby repealed.

\* \* \* \* \*

I hereby certify that the foregoing is full, true, and correct copy of the Ordinance duly and regularly passed and adopted by the Sanitary Board of the Las Gallinas Valley Sanitary District of Marin County, California, at a meeting hereof held on March 22, 2012 by the following vote of members thereof:

AYES: Clark, Greenfield, Loder, Murray and Schriebman  
NOES: None  
ABSENT: None  
ABSTAIN: None

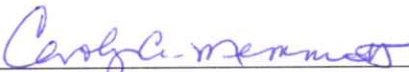
  
\_\_\_\_\_  
/s/Carolyn A. Memmott, District Secretary  
Las Gallinas Valley Sanitary District

APPROVED:

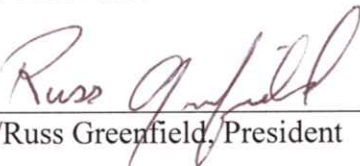
  
\_\_\_\_\_  
/s/Russ Greenfield, President

(seal)





**EXHIBIT A**

**RECORDING REQUESTED BY:**  
Las Gallinas Valley Sanitary District  
300 Smith Ranch Rd.  
San Rafael, CA 94903

**WHEN RECORDED MAIL TO:**  
Susan McGuire  
Las Gallinas Valley Sanitary District  
300 Smith Ranch Rd.  
San Rafael, CA 94903

ADD:  
APN:

**THIS SPACE FOR RECORDER'S USE ONLY**

**CONTRACTUAL ASSESSMENT AGREEMENT  
[Health & Safety Code §§ 5464, 5465, 5474 & 5474.6]**

THIS CONTRACTUAL ASSESSMENT AGREEMENT made this \_\_\_\_\_ day of \_\_\_\_\_, between \_\_\_\_\_ (the "Owner(s)"), whose address is \_\_\_\_\_, San Rafael, CA, \_\_\_\_\_, A.P.N. \_\_\_\_\_, and the LAS GALLINAS VALLEY SANITARY DISTRICT, (the "LGVSD"), a sanitary district, created pursuant to The Sanitary District Act of 1923, Health & Safety Code §§ 6400 et seq., whose address is 300 Smith Ranch Road, San Rafael, CA 94903; and

WHEREAS, the Owner(s) and LGVSD did agree, pursuant to Health & Safety Code §§ 5465 and 5465, to the replacement and repair of existing sewer laterals on Owner(s)' property and that said cost of the lateral replacement or repair shall constitute the cost of an improvement for connection to a sewer system pursuant to Health & Safety Code §§ 5464 AND 5474; and

WHEREAS, LGVSD did fund said cost of the lateral replacement or repair in the sum of \$ \_\_\_\_\_; and

WHEREAS, IN CONSIDERATION for the construction and repair of Owner(s)  
Check all that apply: \_\_\_ **Upper** \_\_\_ **Lower** \_\_\_ **Entire** Sewer Laterals pursuant to that Right to Enter Agreement agreed to by Owner(s) and LGVSD on \_\_\_\_\_ and for LGVSD's having funded the costs of construction and repair of Owners(s) Upper Sewer Laterals for the principal sum of \$ \_\_\_\_\_;

**OWNER(S) AND LGVSD DO HEREBY AGREE AS FOLLOWS:**

1. Said principal sum of \$ \_\_\_\_\_, shall constitute a lien against Owner(s) property, whose address is \_\_\_\_\_, San Rafael, CA, \_\_\_\_\_, A.P.N. \_\_\_\_\_, not unlike that of a regular assessment against said property for the LGVSD's regular annual assessment for sewer charges related to sewer service for purposes of

2. collection of said principal sum and interest; and
3. Said principal sum of \$ \_\_\_\_\_ to accrue interest at the rate of \_\_\_\_\_ percent per annum; and
4. Said lien/assessment amount plus interest shall be payable to LGVSD in semi-annual installments of \$ \_\_\_\_\_ ; and
5. Pursuant to Health & Safety Code §§ 5470 – 5474.10 and 6940 – 6941.9, Owners(s) and LGVSD agree that said semi-annual principal and interest installment amounts shall be collected pursuant to the procedures for regular assessment by addition of said installment payment to the County of Marin Tax Rolls, to be collected at the same time and in the same manner as county taxes are collected; and
6. Said lien/assessment shall be of the same force and effect as other liens for taxes, and their collection shall be enforced by the same means as provided for the enforcement for liens for county taxes.

OWNER(S):  _____ Signature  _____ Print Name  Dated: _____	OWNER(S):  _____ Signature  _____ Print Name  Dated: _____
--	--

**ACKNOWLEDGMENT**

x:\board\ordinances\ordinance 153 final lateral sewer contractual assessment 3 22 2012.docx

**THE BOARD OF DIRECTORS OF THE  
LAS GALLINAS VALLEY SANITARY DISTRICT**

**ORDINANCE NO. 180**

**AN ORDINANCE AMENDING VARIOUS SECTIONS OF THE  
ORDINANCE CODE OF THE LAS GALLINAS VALLEY SANITARY DISTRICT**

The Board of Directors of the Las Gallinas Valley Sanitary District, Marin County, California, does ordain as follows:

Section 1. TITLE 1, CHAPTER 1, ARTICLE II, DEFINITIONS, of the ORDINANCE CODE OF THE LAS GALLINAS VALLEY SANITARY DISTRICT is hereby amended in its entirety as follows:

ARTICLE II. DEFINITIONS. As used in this Code, unless a different meaning is apparent from the context or is specified elsewhere in the Code:

Section 201. APPLICANT shall mean the Person making application for a Permit for a Sewer or plumbing installation and shall be the Owner of premises to be served by the Sewer for which a Permit is requested or his authorized agent.

Section 202. BOARD or BOARD OF DIRECTORS shall mean the Board of Directors of said District.

Section 203. BOD shall mean Biochemical Oxygen Demand, which defines the “strength” or organic content of Wastewater through the measurement of dissolved oxygen, as outlined in the District’s National Pollution Discharge Elimination System Permit.

Section 204. BUILDING shall mean any structure used for human habitation or a place of business, recreation or other purpose containing sanitary facilities.

Section 205. BUILDING SEWER shall mean that portion of any Sewer beginning at the plumbing or drainage outlet of any Building or industrial facility and running to the property line or to a private Sewage disposal system.

Section 206. CAPITAL FACILITIES CHARGE shall mean the fee designed to allow new or additional connections to the District to pay for line and plant capacity necessary to serve those connections.

Section 207. COMBINED SEWER shall mean a Sewer receiving both surface runoff and sewage.

Section 208. COMMON INTEREST DEVELOPMENT shall mean a development characterized by individual ownership of a condominium housing unit or a residential parcel coupled with the shared ownership of (or right to use) common areas and facilities, including, but not limited to, condominium projects, community apartment projects, stock cooperatives and planned unit developments, which contains three (3) or more dwelling units and which has a Sewer Lateral shared by three (3) or more dwelling units.

Section 209. COMMON LATERAL shall mean any Sewer Lateral that connects directly to another Sewer Lateral, in lieu of connecting to the Public Sewer Main.

Section 210. CERTIFICATION OF COMPLIANCE shall mean any documentation issued by the District certifying that all Sewer Laterals associated with a parcel have demonstrated compliance with District Ordinances, Resolutions and Administrative Policies. This includes, but is not limited to, any District documentation indicating that the lateral is constructed correctly (for newly constructed laterals) and/or a Report of Findings that indicates

the lateral shows no indications of defects of concern, illegal connections, sources of inflow, or other condition(s) indicative of a violation of this Ordinance. .

Section 211. CONTRACTOR shall mean an individual, firm, corporation, partnership or association duly licensed by the State of California to perform the type of work to be done under the Permit.

Section 212. CONTRACTUAL SERVICES shall mean any and all telephone, gas, water, electric light and power services; the rental of equipment and machinery; insurance; the services of attorneys, physicians, electricians, engineers, consultants or other individuals or organizations possessing a high degree of technical skill; and all other types of agreements under which the contract provides services which are required by the District but not furnished by its own employees. Purchase of space for legal advertising shall not be subject to the provisions of these regulations

Section 213. COUNTY shall mean the County of Marin, California.

Section 214. DISTRICT shall mean the Las Gallinas Valley Sanitary District, Marin County, California.

Section 215. DISTRICT ENGINEER shall mean the Person holding the position of District Engineer, or other District personnel or consultant as designated by the General Manager (i.e., designee).

Section 216. DISTRICT STANDARDS shall mean the engineering and construction standards that are in effect at the time of inspection and/or Permit as determined by the General Manager or District Engineer or designee, and includes all Ordinances, Resolutions and Administrative Policies.

Section 217. EQUIVALENT SEWER UNIT shall mean the amount of sewage

estimated to be produced by a detached, single family residence.

Section 218. FIXTURE shall mean any sink, tub, shower or water closet or other facility connected by drain to the sewer.

Section 219. FIXTURE UNIT shall mean fixture units as defined in the most recent publication of the California Plumbing Code as updated periodically.

Section 220. FORCEMAIN shall mean a pipeline that is designed to convey sewage under pressure.

Section 221. GARBAGE shall mean solid wastes from the preparation, cooking and dispensing of food and from the handling, storage and sale of produce

Section 222. GENERAL MANAGER shall mean the Person or Persons appointed by the Board to administer and enforce the rules and regulations of the District.

Section 223. GREASE INTERCEPTOR/TRAP. A receptacle designed to collect and retain grease and fatty substances normally discharged from kitchens, food processing, or similar wastes.

Section 224. HEAVY CONSTRUCTION EQUIPMENT shall mean equipment such as bulldozers, carryalls, trucks, graders and all equipment and vehicles with axle load of five (5) tons or more.

Section 225. ILLEGAL CONNECTION shall mean any connection that violates the Ordinance Code of the District. Examples of Illegal Connections include, but are not limited to, roof downspouts, pool overflow piping, sump pump discharge piping, surface drainage features, modified, damaged or otherwise faulty “contra costa” valves or other backflow or backpressure relief features, connections of process discharges causing harm to the District’s collection and/or Ordinance No. 180

treatment infrastructure or that are in conflict with regulatory requirements the District is required to comply with, and sewer lateral cleanouts that are not securely capped to prevent surface drainage to enter from entering the sewer lateral cleanout.

Section 226. IMPACT MACHINE shall mean equipment designed for compacting soil by impact and shall include drop hammers, pneumatically operated hammers, hydraulically operated hammers and pneumatic tampers weighing more than thirty-four (34) pounds.

Section 227. INFILTRATION shall mean water other than sewage which enters into the District's collection system through cracks, breaks, open joints, or other deficiencies which may exist in Laterals or in the District's system.

Section 228. INFLOW shall mean any material other than sewage that is directed toward or connected to the District's collection system through ILLEGAL CONNECTIONS as defined in Section 225.

Section 229. INFLOW AND INFILTRATION are sometimes referred to collectively as "I&I".

Section 230. LATERAL SEWER, SEWER LATERAL OR LATERAL shall mean a gravity and/or pressurized sewer which connects the Plumbing System in a Building to a Sewer Main owned and operated by the District, including the connection itself (i.e., the "wye" or similar connection as described in Section 601) and any associated equipment. The Lateral Sewer shall comprise the upper Lateral or Building Sewer, which extends from the Building to the property line, and the lower Lateral, which extends from the property line to the Sewer Main or within a sewer easement. No part of the Lateral is owned or maintained by the District.

Section 231. LOCAL BIDDER means a firm or individual who regularly maintains a place of business and transacts business in or maintains an inventory of merchandise for sale in

the County in which District is located.

Section 232. MAIN SEWER or SEWER MAIN shall mean a Public Sewer designed to accommodate more than one Lateral sewer.

Section 233. MANAGER shall mean the General Manager of the District.

Section 234. MULTI-FAMILY BUILDING shall mean a residential, attached dwelling unit connected by a common wall or walls to other similar dwellings; for example, apartments but not including condominiums.

Section 235. NOTICE TO REPAIR shall mean the Written notice issued by the General Manager, District Engineer or designee to the Building Owner advising that the Building Owner appears to be in violation of the respective Code or Ordinance with respect to the Building Owner's Sewer Lateral, or in violation of the Code or Ordinance in a manner of the Sewer Lateral's connection to the District's sewer system, which order directs the abatement of the identified violation in a timely manner

Section 236. OATH includes affirmation.

Section 237. OUTSIDE SEWER shall mean a Sanitary Sewer beyond the limits of the District not subject to the control or jurisdiction of District.

Section 238. OWNER shall mean any Person, partnership, association, corporation or fiduciary having legal title (or any partial interest) in any real property situated within the District.

Section 239. PAVEMENT BREAKERS shall mean drop hammers, pneumatically or hydraulically operated hammers designed for breaking pavement by impact and pneumatic jack hammers weighing more than eighty (80) pounds.

Section 240. PERMIT shall mean any Written authorization required pursuant to this or any other regulation of District for the installation of any sewage works.



Section 241. PERSON shall mean and includes any human being, individual, firm, company, partnership, association and or public and municipal corporations, the United State of America, the State of California, districts and all political subdivisions, and governmental agencies.

Section 242. PLUMBING FIXTURE UNIT shall mean fixture units as defined in the most recent publication of the California Plumbing Code as updated periodically.

Section 243. PLUMBING SYSTEM shall mean all plumbing fixtures and traps or soil, waste, special waste and vent pipes, and all Sanitary Sewer pipes within a Building and extending to the Building Sewer connection two (2) feet outside the Building wall.

Section 244. PRESSURE TEST shall mean a District approved air or hydrostatic pressure test on the Sewer Lateral from as close as practical to the building foundation (as determined by the General Manager, District Engineer, or their delegate) to the sewer lateral's connection to the Public Sewer Main in order to demonstrate that the Lateral pipe and the connection to the Public Sewer Main are water tight. Unless specifically required by the General Manager or District Engineer, pressure testing of laterals shall only apply to newly constructed or repaired laterals.

Section 245. PRIVATE PUMPING STATION shall mean a privately-owned pumping, lifting, or sewer ejection facility, including privately-owned forcemain piping, that is used to convey Wastewater to a Sewer Lateral, and subsequently, to the public Main Sewer.

Section 246. PRIVATE SEWER shall mean a Sewer serving an independent sewage disposal system not connected with a Public Sewer and which accommodates one or more Buildings or industries.

Section 247. PUBLIC SEWER shall mean a Sewer lying within a Street or public right-

of-way, and which is controlled by or under the jurisdiction of the District.

Section 248. REPAIR or REHABILITATION or REPLACEMENT shall mean restoration of the Lateral in a manner that eliminates breaks, voids, separations, sags, illegal connections, or other defects that allow non-sewage materials, including but not limited to groundwater, roots, soils, and Infiltration, to enter the Lateral.

Section 249. SANITARY SEWER shall mean a Sewer which carries sewage and to which storm, surface, and ground waters are not intentionally admitted.

Section 250. SANITARY SEWER OVERFLOW or SSO shall mean any overflow, spill, release, discharge, or diversion of untreated or partially treated Wastewater from a Sanitary Sewer system.

Section 251. SECTION, ARTICLE, CHAPTER and TITLE mean, respectively, section, article, chapter and title of this Code.

Section 252. SEWER shall mean a pipe or conduit for carrying sewage.

Section 253. SEWER CONNECTION FEE shall mean Capital Facilities Charge plus other fees set by the District as payment for services supplied on a onetime basis during application for sewer service.

Section 254. SEWER LATERAL INSPECTION shall mean an inspection of a Sewer Lateral that consists of the retention of a licensed plumber, Contractor or Pipe Assessment Certification Program (“PACP”) certified inspector by the Owner, in order to visually examine and inspect a Sewer Lateral in the manner deemed appropriate by the General Manager or District Engineer or designee. Such an inspection shall, at a minimum, include the use of a closed-circuit television (CCTV) inspection, and submittal of the inspection report in digital format acceptable to the District at the time of submittal and inspection log for the purposes of determining whether the

Sewer Lateral complies with the requirements of this Ordinance. For inspections required by section 705, the inspection shall also include a visual, “on-foot” inspection of the entire property served by the lateral, including crawlspace areas under any buildings on the property, to identify any obvious or suspect illegal connections and/or sources of inflow to the lateral. The inflow/illegal connection inspection shall be performed by the same inspector conducting any required CCTV inspection.

Where potential illegal connections are suspected but impossible to prove without invasive efforts (such as the case when a sump pump discharge is routed under concrete), the inspector shall verify operation of the potential illegal connection as necessary to determine that it is not connected to the lateral.

Section 255. SHALL and MUST are mandatory and MAY is permissive.

Section 256. SIDE SEWER shall mean the Sewer line beginning at the foundation wall of any Building and terminating at the Main Sewer and includes the Building Sewer and Lateral Sewer together.

Section 257. SINGLE-FAMILY UNIT. A Single-Family Unit is defined to mean and refer to the place of residence for a single family, and typically includes one (1) kitchen. Property improved for multi-family purposes shall constitute the number of units that the facilities thereon provide, and in calculating any charge for Multi-Family Buildings, the charge shall be a multiple of the number of units in the Multi-Family Building.

Section 258. STORM SEWER or STORM DRAIN shall mean a Sewer which carries storm and surface or ground waters and drainage, but excludes sewage and polluted industrial wastes.

Section 259. STREET shall mean any public highway, road, Street, avenue, alleyway, public place, public easement or right-of-way.

Section 260. SUPPLIES and EQUIPMENT mean any and all articles, materials or things which shall be furnished to or used by District, but excluding services or materials furnished “in kind” in lieu of cash to indigents.

Section 261. SUSPENDED SOLIDS (SS). Solid material that either floats on the surface of, or is in suspension in, water, sewage, or other liquids and can be measured by laboratory filtering; expressed in terms of weight per unit volume, milligrams per liter (mg/l).

Section 262. SS LOADING. The established amount of SS contributed to the collection system by any given parcel within the District.

Section 263. VIBRATING MACHINE shall mean equipment designed for compacting soil by mechanical vibration.

Section 264. WASTEWATER FACILITIES shall mean all facilities for collecting, pumping, treating and disposing of Wastewater or Sewage, also referred to as sewage works.

Section 265. WASTEWATER or SEWAGE shall mean a combination of water-carried wastes from residences, business Buildings, institutions and industrial establishments.

Section 266. WASTEWATER TREATMENT PLANT or SEWAGE TREATMENT PLANT shall mean any arrangement of devices and structures used for treating Wastewater or Sewage.

Section 267. WRITTEN includes every form of legible recording.

Section 268. ADDITIONAL DEFINITIONS. For the purpose of this Ordinance, additional terms shall have the meaning indicated in the latest edition of that certain plumbing code entitled “International Association of Plumbing and Mechanical Officials Uniform Plumbing Code,” adopted by the International Association of Plumbing and Mechanical Officials, and the California Plumbing Code, a copy of which is on file in District offices.

Section 2. TITLE 2, CHAPTER 9 of the ORDINANCE CODE OF THE LAS GALLINAS VALLEY SANITARY DISTRICT is hereby enacted and provides as follows:

**TITLE 2, CHAPTER 9**  
**A CHAPTER RELATING TO THE REGULATION OF INSPECTION,**  
**MAINTENANCE, AND REPLACEMENT OF SEWER LATERALS**  
**“SEWER LATERAL ORDINANCE”**

ARTICLE I. PURPOSE. A Chapter regulating the inspection, maintenance, and replacement of Sewer Laterals within the Las Gallinas Valley Sanitary District.

ARTICLE II. DEFINITIONS

Section 201. Definitions for this Chapter are found in Title 1, Chapter 1, Article II.

ARTICLE III. GENERAL PROVISIONS

Section 301. Purpose. The Las Gallinas Valley Sanitary District (“District”) finds and determines that during heavy rains, water is introduced into the District’s system from Infiltration and Inflow (“I&I”). A portion of this I&I is believed to be introduced into the District’s Sewer Mains from Sewer Laterals or other unpermitted sources or connections. The District is required to convey, treat, and otherwise manage this I&I. This Chapter meets the requirement set forth in the District’s Wastewater Treatment Plant National Pollution Discharge Elimination System (“NPDES”) Permit regarding inspection of Sewer Laterals to help in identifying and addressing I&I from Laterals.

Section 302. Short Title. This Chapter shall be known as the “Sewer Lateral Ordinance.”

#### ARTICLE IV. NEW CONSTRUCTION

Section 401. Construction of new, repaired, replaced, or rehabilitated Laterals shall conform to District Ordinances, Resolutions and Administrative Policies (specifically Title 2, Chapter 1, Article V, “Building Sewers, Lateral Sewers and Connections”).

#### ARTICLE V. PERMITS

Section 501. Prior to constructing a Lateral or connecting a new Building to an existing Lateral, or undertaking a Repair, Replacement or Rehabilitation of a Lateral, the Owner shall apply for and obtain a permit for the work from the District in accordance with Title 2, Chapter 1, Article V, “Building Sewers, Lateral Sewers and Connections.” All fees must be paid in accordance with Title 2, Chapter 1, Article IX, “Permits and Fees”. The application shall give a description of the character of the work proposed to be done and the location, ownership, occupancy and use of the premises in connection therewith. The General Manager, District Engineer or designee may require plans, specifications or drawings and such other information as may be deemed necessary.

#### ARTICLE VI. OWNERSHIP, MAINTENANCE AND REPAIR.

Section 601. As required by Title 2, Chapter 1, Article V, “Building Sewers, Laterals Sewers and Connection,” Sewer Laterals shall be owned, maintained and repaired by the Owner of the property, which the Lateral serves. The entire service Lateral, from the Building connection to and including the “wye” connection or other-tie-in to the Sewer Main, shall fall within the Owner’s responsibility for installation, maintenance and repair.

Section 602. Property Owners must clean, maintain and Repair Laterals serving their property sufficient to keep the Lateral in operable condition at all times, as defined herein. The property Owner shall perform such duties as may be required to respond to and correct

conditions that do not meet this standard:

- (a) The Sewer Lateral shall be kept free from roots, grease deposits, and other solids which may impede or obstruct the flow.
- (b) All joints shall be watertight and all pipes shall be sound, which includes being free from any structural defects such as fractures, cracks, breaks, openings, or missing portions.
- (c) In order to prevent inflow from entering a lateral from a cleanout, all cleanouts shall be securely sealed with a proper cap or approved, unmodified, fully functional overflow or backflow device at all times.
- (d) There shall be no illegal connections to the Lateral.
- (e) There shall be no observed overflows, seepage, blockages, other deficiencies (such as Sewer too low to allow for proper gravity flow) in the Lateral as determined by the General Manager, District Engineer or designee.

Section 603. Sewer lateral defects may be discovered by District through the District's operations which include smoke testing, response to an SSO, closed circuit televising of underground infrastructure, Pressure Testing, or other District activities.

#### ARTICLE VII. MANDATORY INSPECTIONS AND/OR PRESSURE TESTING

Section 701. Applicability. This Section shall apply to residential properties, commercial properties, publicly owned buildings, Common Interest Developments, apartment buildings and any structure which has a Sewer Lateral.

Section 702. Inspection Report. Following all inspections, the Owner shall submit to the District Engineer a sewer service lateral inspection report per Section 901.

Section 703. Certification of Compliance. The District will certify compliance of a

newly constructed or repaired lateral following verification of its meeting the Pressure Test standards established by the District. The District Engineer, in their sole discretion, will verify results of any testing. In order for an owner to obtain Certification of Compliance, a newly constructed or repaired sewer lateral shall meet the pressure test criteria described in the District sewer lateral testing and reporting protocols.

Section 704. Health and Safety Basis For Requiring A Sewer Lateral Inspection. An owner, or if applicable, all multiple owners of a common sewer lateral, shall have the sewer service lateral of his or her real property inspected in accordance with the requirements of this Chapter, and/or as directed and within the time period indicated by the General Manager or District Engineer, upon the occurrence of any of the following events:

- (a) Overflow or Malfunction. Whenever the General Manager or District Engineer determines that the sewer service lateral has recently overflowed or has recently malfunctioned, or that a District sewer system overflow resulted from roots, grease, debris, or excess flow from a sewer lateral.
- (b) Lateral Failure or Lack of Maintenance. Whenever the General Manager or District Engineer finds that the lateral has not been properly maintained.
- (c) Public Health Threat. Whenever the General Manager District Engineer has cause to believe that there is a threat to the public health, safety, or welfare due to the condition of a sewer service lateral.

After reviewing the results of the Inspection, the Owner shall be provided with a District issued Report of Findings. In the event the General Manager or District engineer is not satisfied with the results of the Inspections performed under a Health and Safety Basis, the Report of Findings shall describe any remedial actions required of the Owner, which may include repair or



replacement of the lateral.

Section 705. Other Events Requiring A Sewer Lateral Inspection. Except for those circumstances noted in Section 707, an owner, or if applicable, all multiple owners of a common sewer lateral(s), shall have the sewer service lateral(s) of his or her property inspected in accordance with the requirements of this Chapter upon the occurrence of any of the following events:

- (a) Additions and Improvements. Prior to the final inspection of work performed under a county or city building permit for a remodel where said remodel has a value of \$30,000 or greater. The District will notify the relevant jurisdiction (city or county) of this requirement so that issuance of a building permit is conditioned upon meeting this inspection requirement.
- (b) Sale or Transfer of Property. Upon proposed sale or transfer of property, the seller shall obtain and submit a lateral inspection report to the District prior to the close of escrow.
- (c) Title Transfer. The sale or transfer of an entire property estate or the fee interest in that real property estate, excluding the sale or transfer of partial interest such as a leasehold. The following are not Title Transfers for the purposes of this

Ordinance:

- (1) A transfer to an heir by fiduciary in the course of the administration of a decedent's estates, guardianship, conservatorship or trust;
- (2) A transfer from one co-owner to one or more other co-owners, or from one or more co-owners into or from a revocable trust, if the trust is for the benefit of the grantor or grantors;

- (3) A transfer made by a trustor to fund an inter vivos trust;
- (4) A transfer made to a spouse, or to a registered domestic partner as defined in Section 297 of the Family Code, or to a person or persons in a Lineal Consanguinity Relationship with one or more of the transferors;
- (5) A transfer between spouses or registered domestic partners resulting from a decree of dissolution of marriage or domestic partnership, or resulting from a decree of legal separation or from a property settlement agreement incidental to a decree; and
- (6) A transfer from a Property Owner to a financial institution as a result of a foreclosure or similar process. A transfer from a financial institution to a new Property Owner is a Title Transfer for purposes of this Ordinance.

After reviewing the results of the Inspection, the Owner shall be provided with a District issued Report of Findings, which shall describe any remedial actions required of the Owner, which, for inspections done pursuant to this Section only, will be limited to elimination of illegal connections (sources of inflow). Repair or replacement of the lateral will not be required as a result of inspections performed pursuant to this section, however additional remedial actions may be described that the owner is advised to take in order to ensure reliable function of the lateral. See section 707 regarding exception to inspections required under this section.

Section 706. Notification of Right of Entry By District. When the District is replacing a sewer main or conducting repairs of a sewer main on a road where one or more sewer laterals connect to the sewer main, or responding to and evaluating the cause of an SSO, and requires access to property, owners will be notified by the District.

Section 707. Exceptions to Inspection for Recent Replacements, Repairs, or Inspections.

The following are exceptions to the inspection requirements of Article VII, section 705.

- (a) Installation of Lateral Within Prior 20 Years. An owner otherwise required to perform a sewer lateral inspection under this Article shall not be required to perform such an inspection if the owner (or the owner's predecessor-in-interest) has originally installed the sewer lateral, or replaced in full the pre-existing sewer lateral to the then-current District Standards and performed under a District-issued permit within twenty (20) years prior to the date of the application for a current building permit, or of listing the property for sale.
- (b) Certification of Compliance Within Prior 20 Years or District project. An owner otherwise required to perform a sewer lateral inspection under this Article shall not be required to perform such an inspection if the Owner has received a District Certification of Compliance or a Report of Findings indicating the absence of any Illegal Connections within the twenty (20) years prior to the date the inspection would otherwise be required or if the sewer lateral was replaced during a District project or as part of the Districts Sewer Lateral Replacement Program.
- (c) Proof of Prior Replacement or Rehabilitation of a Sewer Service Lateral. Owner shall provide proof of any prior replacement or repair of a sewer service lateral in the form of a certificate, a paid bill or any sufficient documentation that ensures such prior replacement or rehabilitation of a sewer service lateral occurred pursuant to a. and b. above. The form and content of the document or proof must

be deemed sufficient by the General Manager or District Engineer or designated representative in their sole discretion.

Discovery of suspected evidence of non-compliance of this Ordinance through District activities described in Section 603 shall negate applicability of Section 707.

Section 708. Fees. Prior to conducting any work by District staff, and in order to cover District staff time and administrative costs, the District will assess fees according to the Districts miscellaneous fee schedule.

Fees shall be payable immediately by the current property upon requesting District services. Additional information regarding fees is available at the District Offices and on the District Website.

Section 709. The District may contract with a firm to carry out any inspections or any inspection report review authorized by this Ordinance.

#### ARTICLE VIII. ACCESS TO PREMISES

Section 801. In accordance with Health and Safety Code § 6523.2 the District Engineer or designated representative is hereby authorized to inspect laterals with notice to the property owner for the following purposes:

- (a) To determine the size, depth, and location of any sewer connection.
- (b) To determine the end outlet of any sewer connection by depositing harmless testing materials in any plumbing fixture attached hereto and flushing the same, if necessary.
- (c) To determine, by measurements and samples, the quantity and nature of the sewage or wastewater being discharged into any sewer.
- (d) To determine the location of the roof, swimming pool, floor and surface drains,

and whether or not they physically connect to a sewer.

(e) To assess the condition of the lateral where the District has information indicating that the lateral may be allowing inflow or infiltration.

(f) To make any determinations regarding public health, safety or welfare.

Section 802. Powers and Authorities of Inspectors. The officers, inspectors, managers, and any duly authorized employees of the District shall carry evidence establishing their position as authorized representatives of the District, and upon exhibiting the proper credentials and identification, shall be permitted to enter in and upon any and all buildings, industrial facilities, and properties for the purposes of inspection, re-inspection, observation, measurement, sampling, testing or otherwise performing such duties as may be necessary in the enforcement of the provisions of the ordinance, resolutions and administrative policies of the District.

#### ARTICLE IX. INSPECTION REPORT REQUIREMENTS

Section 901. Inspection Report Requirements. An Inspection Report required by this Ordinance shall be prepared in accordance with and pursuant to all District regulations, standards and requirements. For current report requirements, Contact District Offices or visit the District Website.

#### ARTICLE X. REQUIRED REPAIRS

Section 1001. Notice to Repair. Upon receipt of the sewer service lateral inspection report or in the event of a failed pressure test, pursuant to this Chapter, the District Engineer or designee will determine whether it indicates any deficiencies in the operation of the sewer service lateral and, thereafter, shall provide the owner(s) with a Notice to Repair as may be deemed appropriate by the General Manager or District Engineer. The Notice to Repair may specifically identify the deficiencies to be corrected and shall establish a deadline within which

the owner(s) shall complete the required corrective actions. The corrective action may include a requirement that the lateral be replaced altogether and may include the installation of cleanouts and backwater prevention devices if those devices are otherwise required by this Ordinance or any other provisions of the Ordinance Code. Failure to make repairs as required by the Notice of Repair may result in the District's recording of a Notice of Violation with the Marin County Recorder and any and all remedies available to the District.

Section 1002. Disconnection of Illegal Connections. For inspections conducted pursuant to Section 705, lateral replacement will not be required, however corrective action up to and including lateral replacement may be advised. Illegal connections or sources of inflow identified during inspections pursuant to Section 705, however, must be eliminated or otherwise disconnected from the lateral within a 90-day grace period as measured from date of discovery. Failure to comply within this grace period will result in a notice of Violation being filed with Marin County Recorder, in addition to pursuit of any legal remedies the District is entitled to. Adequate verification of disconnection shall include written summary of observed conditions during site review by a PACP inspector or licensed plumber pursuant to Section 901.

Section 1003. Additional or Subsequent Violations. If any violations of this Ordinance are discovered on a property after corrective action, up to and including lateral replacement, has been previously ordered by the District, a Notice of Violation may be filed by the District with the Marin County Recorder, in addition to pursuit of any legal remedies the District is entitled to, until verification of corrective action is supplied to District offices. The grace period described in Section 1002 shall not apply to violations described in this section. Adequate verification of corrective action shall include written summary of observed conditions during site review by a PACP inspector or licensed plumber pursuant to Section 901, or other verification if required by

the District.

Section 1004. Time Limits. Time limits described in sections 1002 and 1003 supersede those described in Title 2, Chapter 1, Article X of the Las Gallinas Valley Sanitary District Ordinance Code.

SECTION 1005. Pool Overflow Piping. Except for pools constructed prior to the effective date of this Ordinance, pool overflow piping is considered a source of inflow and, therefore, if connected to a sewer lateral, is considered an illegal connection and is not allowed. Due to concerns regarding environmental impact of pool overflow water, owners constructing or disconnecting pool overflows from sewer laterals are advised to coordinate any pool overflow piping construction or changes through the Marin County Stormwater Pollution Prevention Program. Draining of pool contents to sewer laterals for complete pool draining purposes is not considered inflow and is permissible under certain circumstances if a pool discharge permit is issued to the Owner by the District. Contact District Offices or visit the District Website for more information related to draining pools.

#### ARTICLE XI. MULTIPLE CONNECTIONS

Section 1101. It shall be the policy of the District to require one Sewer Lateral serving one single family home. However, the District recognizes that the existing sewer service system within the District contains groups of two or more properties that are serviced by one pre-existing Sewer Lateral. Where there is no problem with a Sewer Lateral that serves multiple properties, in the opinion of the General Manager or District Engineer or designee, then the District may allow the multiple service Lateral. Where Repairs are necessary, the Owners of the residences served by the Lateral shall jointly be responsible for the Repairs. Where Repairs and/or Replacement of such a Lateral is necessary, the District may require the construction of a new Sewer Lateral for each

residential single-family home or the construction of a new larger Sewer Lateral to accommodate the multiple residences.

Section 1102. Discovery of Common Lateral. If the District identifies that the Sewer Lateral conveys flow from one or more Common Laterals, the District will inform the property Owner. The property Owner remains responsible for the full cost of testing, and repair or replacement of the Sewer Lateral from the Public Sewer Main to the initial Building in question. Where multiple residential connections connect to one Sewer Lateral, it is the property Owner/Owners' responsibility to determine how costs related to Lateral, inspections and repairs will be shared. If during the inspection it is determined that a sewer lateral is serving more than one residence, the District can require the construction of an additional lateral to comply with present District standards.

#### ARTICLE XII. DISTRICT'S AUTHORITY UPON FAILURE TO REPAIR.

Section 1201. Failure to Repair upon District Notification. Should an Owner fail to conduct the required Repairs upon issuance of a Notice to Repair by the District, the District shall have several options in order to ensure that the Repair or Replacement is completed:

- (a) Public Health: The District may determine that a property constitutes a hazard to public health and take all actions authorized by the Health and Safety Code or other relevant law.
- (b) Disconnection of Sewer Lateral to Sewer Main: The District shall have the right to commence proceedings in the County of Marin Superior Court to seek a court order disconnecting the Sewer Lateral from the Sewer Main, thus leaving the home, Building or industrial facility without sewer service.
- (c) Corrections of Violations: Section 6523 of the California Health and Safety Code



provides than in order to enforce the provisions of any Ordinance of the District, the District may correct any violation of an Ordinance of the District. The cost of such correction may be added to any sewer service charge payable by the Person violating the Ordinance or the Owner or tenant of the property upon which the violation occurred, and/or the District may place a lien on the property wherein the violation occurred or the District may pursue a civil action for recovery of the costs.

ARTICLE XIII. PUNISHMENT FOR VIOLATION OF PROHIBITED DISCHARGES

Section 1301. Section 6523 of the California Health and Safety Code provides that the violation of any ordinance, rule or regulation of a sanitary district by any Person is a misdemeanor punishable by imprisonment in the County jail not to exceed 30 days or by a fine not to exceed one thousand dollars (\$1,000) or both. Each and every connection, occupancy, prohibited discharge in violation of this Ordinance shall be deemed a separate violation and each and every day or part of a day a violation of the Ordinance, rule or regulation continues shall be deemed a separate offense hereunder and shall be punishable as such.

ARTICLE XIV. SEVERABILITY

Section 1401. If any section, subsection, sentence, clause or phrase of this Ordinance is for any reason held invalid, unconstitutional or unenforceable, such holding shall not affect the validity of the remaining portions of this Ordinance. The Board of Directors hereby declares that it would have passed this Ordinance and each section, subsection, sentence, clause of phrase thereof, irrespective of the fact that anyone or more sections, subsections, sentences, clauses or phrases is for any reason held invalid, unconstitutional or unenforceable.

Section 3. Upon adoption of this Ordinance, it shall be entered in full in the minutes of the Board of Directors, shall be posted in one place in the District, shall be published once in the

Marin Independent Journal, and shall take effect immediately upon the expiration of one (1) week of said publication and posting.

Section 4. All other ordinances and parts of ordinances inconsistent herewith are hereby repealed.

\*\*\*\*\*

I hereby certify that the foregoing is a full, true and correct copy of the Ordinance duly and regularly passed and adopted by the Board of Directors of the Las Gallinas Valley Sanitary District of Marin County, California, at a meeting hereof held on November 21, 2019, by the following vote of members thereof:

AYES: Clark, Elias, Murray, Schneidman, Yezman

NOES: None.

ABSENT: None.

ABSTAIN: None.



Teresa Lerch, District Secretary  
Las Gallinas Valley Sanitary District

APPROVED:

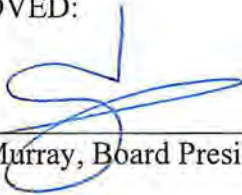

Craig Murray, Board President

(Seal)





# Agenda Summary Report

**To:** Mike Prinz, General Manager *MP*  
**From:** Michael P. Cortez, PE, District Engineer  
**Mtg. Date:** August 1, 2019  
**Re:** Approve Uniform LGVSD-SRSD Standard Specifications for Lateral Sewers  
**Item Type:** Consent  Discussion  Information  Other   
**Standard Contract:** Yes  No  (See attached) Not Applicable

## BACKGROUND:

The Las Gallinas Valley Sanitary District (LGVSD) approved LGVSD Standard Specifications and Drawings in 2000, which cover how the District's owned and operated facilities and homeowner sewer laterals are designed and built. This document has not been periodically revised and updated since its inception.

Both LGVSD and San Rafael Sanitation District (SRSD) jurisdictions cover portions of the City of San Rafael. SRSD also has approved Standard Specifications for Side Sewers and Laterals, which they intended to revise. Both agencies have determined that it would be in the interest of their customers to develop a unified standard that provides consistent requirements for residents of San Rafael, regardless of what District they reside in. Not having consistent material or design requirements can cause confusion for residents who own and maintain properties in both Districts. A unified standard would also help contractors that perform work within both agencies' jurisdictions in San Rafael.

The attached current completed version of the Uniform LGVSD-SRSD Standard Specifications for Lateral Sewers underwent a review process by staff of both agencies. Staff members of both agencies also reviewed the requirements of neighboring sanitary districts and incorporated appropriate features that were used by these other agencies. All of this was done to provide a working document with consistent materials and design requirements.

## PREVIOUS BOARD ACTION:

LGVSD Standard Specifications and Drawings original approval of the in 2000.

## ENVIRONMENTAL REVIEW:

N/A

## FISCAL IMPACT:

N/A

## STAFF RECOMMENDATION:

Board to approve the Uniform LGVSD-SRSD Standard Specifications for Lateral Sewers.

**SAN RAFAEL SANITATION DISTRICT**

**LAS GALLINAS VALLEY SANITARY DISTRICT**

MARIN COUNTY, CALIFORNIA



**SPECIFICATIONS  
FOR  
LATERAL SEWERS**

**DRAFT**

**2019**

Adopted by the SRSD Board on \_\_\_\_\_

Adopted by Las Gallinas Valley Sanitary District Board on \_\_\_\_\_.

**SPECIFICATIONS FOR LATERAL SEWERS**

**TABLE OF CONTENTS**

Section 1. GENERAL INFORMATION ..... 1

    1-01 Jurisdiction ..... 1

    1-02 Ownership and Maintenance ..... 1

    1-03 Liability ..... 1

    1-04 California Environmental Quality Act Requirements ..... 2

    1-05 Prohibited Wastes ..... 2

Section 2. Permits and Inspections ..... 3

    2-01 Permits & Regulations..... 3

    2-02 Building Permit..... 3

    2-03 Plans Required..... 3

    2-04 Encroachment Permit (As Required) ..... 3

    2-05 Sewer Connection Permit ..... 3

    2-06 Permits and Non-Transferable ..... 4

    2-07 Time Limit on Permits ..... 4

    2-08 Compliance with Regulations ..... 4

Section 3. Design Requirements ..... 4

    3-01 Separate Sewers ..... 4

    3-02 Pipe Size ..... 4

    3-03 Pipe Slope ..... 5

    3-04 Pipe Cover..... 5

    3-05 Pipe Materials..... 5

    3-06 Cleanouts ..... 5

    3-07 Backwater Prevention Device (Blow-off Cleanout) ..... 5

    3-08 Inceptors Required & Maintenance ..... 6

    3-09 Residential Sewage Pump Systems ..... 6

    3-10 Taps into Main Sewer ..... 7

    3-11 Pipebursting Rehabilitation of Laterals ..... 7

    3-12 Cured-in-Place (CIPP) Rehabilitation of Laterals ..... 8

    3-13 Closed Circuit Television Inspections(CCTV) ..... 8

    3-14 Old Lateral Sewers..... 8

    3-15 Abandoned or Unused Lateral Sewers..... 8

    3-16 Existing Septic Tanks..... 8

Section 4. Construction ..... 9

    4-01 Location of Lateral Stub ..... 9

    4-02 Bypass Pumping ..... 9

    4-03 Laying Pipe..... 9

4-04 Inspections.....	9
4-05 Trenches Lateral Sewers – Excavation and Backfilling .....	9
4-06 Clay Plugs .....	9
4-07 Trenches in Slopes .....	10
4-08 Testing of Gravity Sewers .....	10
4-09 Testing of Pressure Sewers.....	10
4-10 Special Conditions .....	10

TABLE 1 – PRIVATE LATERAL SEWER PIPE MATERIAL LIST.....	11
---	----

Section 5. Details

- Lateral Detail 1 – 4” Lateral Sewer Detail
- Lateral Detail 1.1 – 4” Lateral Sewer Detail Over 90 LF Long
- Lateral Detail 2 – Backwater Check Valve
- Lateral Detail 3 – Lateral Connection to Sewer Main
- Lateral Detail 4 – Typical Trench Section
- Lateral Detail 5 – Steep Slope Lateral Installation
- Lateral Detail 6 – Residential Sewerage Pumping System

# SAN RAFAEL SANITATION DISTRICT LAS GALLINAS VALLEY SANITARY DISTRICT

## SPECIFICATIONS FOR LATERAL SEWERS

All lateral sewers within the San Rafael Sanitation District (District) and Las Gallinas Valley Sanitary District must conform to these specifications and each District's Standard Specifications and Drawings copies of which are available from the District offices. These definitions specifications and details supersede District's Standard Specifications and Drawings, for laterals only. The remainder of the codes and Specifications remain in effect.

Following is a summary of the specifications regarding lateral sewers.

*Lateral or Building Sewer.* The privately owned and maintained sewer, which connects the plumbing system of the building to the public sewer main. The lateral or building sewer begins at and includes the connection to the public sewer main and terminates at the point of connection to the building plumbing system, which is two (2) feet or less from the building foundation.

*Upper Lateral.* That portion of the lateral sewer lying within private property. (Typically that portion of the lateral sewer between the connection to the building's waste plumbing and public right-of-way or property line.) The upper lateral sewer is privately owned and maintained.

*Lower Lateral.* That portion of the lateral sewer lying within a public street or sewer right-of-way/easement. (Typically that portion of the lateral sewer between the main sewer and property or right-of-way line.) The lower lateral sewer is privately owned and maintained.

*Main Sewer.* The public sewer pipe which accommodates more than one lateral sewer and is normally six (6) inches or more in diameter. The District maintains the main sewer.

### Section 1. GENERAL INFORMATION

1-01 Jurisdiction. The District has jurisdiction over all property to receive sewer service within the District boundaries. District jurisdiction includes, but is not limited to: issuing permits to connect to the main sewer, specification of design, type of material, construction requirements, inspection, and testing.

1-02 Ownership and Maintenance. Each building's lateral sewer, including the sewer ejector pump system if applicable, is owned and maintained by the property owner from the building to the connection at the sewer main.

1-03 Liability. The District and its officers and employees shall not be liable for injury or death to any person, or damage to any property, arising during or growing out of, the performance of any work described herein.

1-04 California Environmental Quality Act Requirements. Any person requesting a sewer connection permit must also comply with all applicable environmental guidelines, including the District's Local Guidelines adopted pursuant to the Environmental Quality Act of 1970, and must make all deposits required and pay all fees established by the District to process applications to comply with said Act.

1-05 Prohibited Wastes. Except as hereinafter provided, it is unlawful for any person to discharge, or cause to be discharged, any of the following described waters or wastes into any manhole or sanitary sewer connecting to the main sewer:

a) Drainage. Leaders from roofs and surface drains for rainwater. Surface or subsurface drains for rainwater, storm water, seepage, industrial cooling water, or unpolluted industrial process waters.

b) LGVSD/SRSD will allow swimming pools, spas, or swimming pool/spa filter backwash to be drained into the sanitary sewer system provided that the property owner adheres to the following requirements:

Notification:

Notification must be provided to LGVSD/SRSD a minimum of 48 hours prior to draining swimming pools, spas, or swimming pool/spa filter backwash into the sanitary sewer system.

Air Gap:

The drained and/or pumped water must pass through an air gap tank prior to discharge into the sewer to prevent overflows.

Lateral Cleanout:

Discharge must be into a sanitary sewer cleanout located on the property's sewer lateral. If the property's upper lateral does not have an existing cleanout, then the installation of a new lateral cleanout may be required.

Max Flowrate:

The flowrate of the discharge into the sanitary sewer shall not exceed 50 gallons per minute at any time.

Weather:

Draining must occur during dry weather. The discharge of swimming pools or spas into the sanitary sewer system during rain events will not be allowed.

b) Septic tank sludge.



c) Industrial waste or any solid, semisolid, or liquid substance resulting from any industrial manufacturing, commercial process, or from any garage, service station, or wash rack, without first having obtained a permit to discharge.

d) Liquid or vapor having a temperature higher than 150° F.

e) Water or waste which contains more than 100 parts per million, by weight, of fat, oil, or grease.

f) Food waste that has not been shredded so that all particles will be carried freely under the flow conditions normally prevailing in the main sewer, with no particle greater than one-half inch in any dimension.

g) Ashes, cinders, sand, mud, straw, shavings, metal, glass, rags, feathers, tar, plastics, wood, paunch manure, paint, solvents, or any other solid or viscous substance capable of causing obstruction to the flow in sewers or causing other interference with the proper operation of the sewage works.

h) Waters or wastes having a pH lower than 5.5 or higher than 9.0 or having any other corrosive property capable of causing damage or hazard to structures, equipment, and personnel of the sewage works.

i) Waters or wastes containing toxic or poisonous substance(s) in sufficient quantity to injure or interfere with any sewage treatment process, constitute a hazard to humans or animals, or create any hazard in the receiving waters of the sewage treatment plant.

j) Waters or wastes containing suspended solids of such character or quantity that unusual attention or expense is required to handle such materials at the sewage treatment plant.

k) Noxious or malodorous gas or substance capable of creating a public nuisance.

l) Trash container discharge, except where there is an enclosure. The enclosure shall be covered by a roof to prevent rainfall from entering the enclosure. Roof drainage shall flow away from trash enclosure. The enclosure shall be constructed with wall, berms and/or slopes that prevent runoff from entering into or flowing from the enclosure. District approval is required.

## Section 2. Permits and Inspections

2-01 Permits & Regulations. Following is a summary of the permits and regulations that are generally applicable to the installation of lateral sewers. This list is not intended to be all inclusive.

Contractors performing work requiring a permit by the District shall be licensed by the State of California. Work on public property, streets, roads and other rights-of-way shall be performed only by duly licensed Contractors.

1. All sewer work requiring shoring shall be performed by a licensed contractor holding a Class "A" or Class "C-34".
2. All work on private sewer laterals shall be performed by a licensed contractor holding a Class "A", Class "C-34", "C-36" or "C-42".
3. All trench work and pavement repair within any public right-of-way shall be performed by a Class "A" or "C-12" licensed contractor.
4. All CCTV work shall be performed by licensed plumber, contractor or technician with a current NASCO Certification.

Property owners may perform private sewer work on their own property.

2-02 Building Permit. For new buildings and remodels, a building permit issued by the building department of jurisdiction must be obtained prior to issuance of a sewer connection permit by the District.

2-03 Plans Required. Plans approved by the building department of jurisdiction must be furnished to the District upon making application for a sewer connection permit for new structures. Said plans must show the location of the proposed structure, floor plans showing plumbing fixtures, including any floor drains, and the location of the lateral sewer, public sewer main, and sewer easements. Plans shall be stamped by a registered Civil Engineer in California. Plans should be in a PDF (electronic) format or 24"x36" hard copy. The District may require a survey by a registered land surveyor or engineer if it is necessary to determine: a) the invert elevation of the lateral sewer and/or building floor; and/or b) that the proposed sewer installation is within the property line or easement.

2-04 Encroachment Permit (As Required). When lateral sewer construction extends into a street or public right-of-way, an encroachment permit must be obtained from the agency having jurisdiction over said street or public right-of-way, and all construction must comply with the State, County, and City/Town laws, ordinances, rules and regulations pertaining to the cutting of pavement, sidewalk and restoration, traffic control, opening, barricading, lighting, and protection of trenches, backfilling and paving. The encroachment permit and/or other permits required must be obtained prior to issuance of a sewer connection permit by the District.

2-05 Sewer Connection Permit. A permit from the District is required for any alteration, repair, replacement, new construction, connections, additional discharge, or abandonment/disconnect of lateral sewers that flow to the District's public sewer system. Note that plumbing changes within the building are regulated by the building department of the jurisdiction in which the building is located. Work performed without a valid District Permit will be subject to removal, reconstruction, and additional fees to the property owner. To obtain a permit from the District:

- a. Complete the District's application form for the proposed sewer lateral work.
- b. Provide a set of approved plans showing work to be performed and plumbing fixtures including Building Permit Number. Lateral sewer plans shall be stamped by a registered Civil Engineer in California.
- c. Provide a copy of encroachment permits (if applicable).
- d. Copies of recorded easements for laterals crossing private property of other property owners.
- e. Payment of applicable fees.

2-06 Permits are Non-Transferable. Permits are issued for a specific property giving the property's street address and Assessor's Parcel Number. Permits may not be transferred to another property without written approval of the District Board of Directors.

2-07 Time Limit on Permits. The sewer connection permit becomes void and the fees paid are forfeited under the following conditions: a) work is not commenced within one year from date of issue; or b) after partial completion, work is discontinued for a period of one year. Work may not begin/resume until a new, valid sewer connection permit is obtained. The new sewer connection permit will be issued upon application and payment of applicable fees.

2-08 Compliance with Regulations. A copy of all required permits must be kept at the job site when the lateral sewer is being constructed.

### **Section 3. Design Requirements**

3-01 Separate Sewers. Each structure requiring sewer service must be separately and independently connected to the main sewer. Upon application, the District may grant an exception in the following situations: a) multiple structures on one lot that cannot be subdivided; or b) condominiums having CC&R's providing for sewer maintenance by the homeowner's association. Exceptions are granted at the discretion of the District.

3-02 The inside diameter of lateral sewers shall meet the following requirements:

1. The pipe must conform to the size requirements for horizontal drainage based on fixture unit loading as set out in the California Plumbing Code. Minimum pipe inside diameter shall be as follows:

<b>Number of Fixture Units</b>	<b>Min Inside Diameter</b>
Less than 150	4 inch
Greater than or equal to 150	6 inch

- a. In no event will a lateral sewer be permitted to connect to a sewer of lesser inside diameter on the downstream side.
- b. When more than one building sewer is allowed to be connected to a single side sewer, the lateral sewer from the point of intersection of one or more building sewers to the main sewer shall be calculated and submitted to the District for the proper size, and the approval shall be at the District's discretion.

3-03 Pipe Slope. The minimum slope for a four-inch diameter lateral sewer is 2.0 foot per 100 feet (2.0%), unless specifically approved by the District. The minimum slope for a lateral sewer greater than four inches is 1.0 feet per 100 feet (1.0%). The maximum slope of any portion of a lateral sewer shall not be greater than 150 feet per 100 feet (150%).

3-04 Pipe Cover. The minimum cover over the top of a lateral sewer must be: a) See Table 1 when pipe is in Non Traffic Areas; and b) three (3) feet when pipe is in Traffic Areas. When the foregoing pipe cover cannot be maintained, special pipe bedding, rip-rap, and/or concrete cap may be required by the District. If Pipebursting a lateral sewer that has less than three (3) feet of cover within the street right-of-way and pipebursting is approved by the District, the Contractor shall sawcut and remove existing pavement and install shallow pipe protection in accordance with Standard Drawing.

3-05 Pipe Materials. See Table 1 - Private Lateral Sewer Pipe Materials List

3.06 Cleanouts.

- A. The following are requirements for cleanouts on sewer laterals:
  1. Cleanouts shall be installed at the following locations on sewer laterals:
    - a. Within two (2) feet of the building foundation.
    - b. At or near the property line or public right of way line if required by the District.
    - c. At intervals not to exceed ninety (90) feet of laid pipe length.
    - d. At any single bend greater than forty-five degrees (45°).

- e. At intervals along the lateral sewer system where the cumulative total of deflection from the point of connection to the main sewer or from another cleanout equals or exceeds ninety degrees (90°).
2. The cleanout(s) nearest the building foundation shall be provided with a Backwater Prevention Device (BPD).
3. Cleanouts shall be a two-way or a "Tee" wherever possible.

3-07 Backwater Prevention Device (Blow-off Cleanout). All lateral sewers must be equipped with a backwater prevention device (BPD) as shown in Lateral Details LD-1 and LD-2. New BPD is required for any and all repairs or alterations to existing lateral sewers that do not have an existing and properly functioning backflow prevention device in place. A BPD is required at every location where sanitary sewer piping exits a building. The BPD shall be located within two (2) feet of the building foundation. The required elevation of the overflow rim of the backwater prevention device must be at least three inches above finish grade and at least six inches below the lowest plumbing fixture. The Property Owner or Contractor is responsible to confirm that the BPD is at the proper elevation. If any subsequent modification of the property results in the BPD being at an improper elevation, the Property Owner or Contractor shall adjust the BPD to the proper elevation at their cost. In driveways or other paved areas, a pipe may be extended to the side from a wye to the backwater prevention device. If the required elevation of the BPD overflow rim is not feasible as determined by the District, a check valve must be installed in the lateral sewer ahead of the backwater prevention device in accordance with Lateral Details LD-1 and LD-2.

3-08 Interceptors Required & Maintenance. Grease, oil, and sand interceptors must be installed in conjunction with commercial sewers when necessary, in the opinion of the District, for the proper handling of liquid wastes containing grease in excessive amounts, flammable wastes, sand, or other substances capable of causing: a) a public nuisance, or b) damage or hazard to structures, equipment, and personnel of the sewage works. Interceptors must be: a) a type and capacity approved by the District and the wastewater treatment authority (LGVSD or Central Marin Sanitation Agency), b) easily accessible for cleaning and inspection, and c) maintained in a continuously efficient operation at all times by the property owner at the property owner's expense.

3-09 Residential Sewage Pump Systems. Where gravity service is not feasible, special application may be made to the District to allow installation of a residential sewage pump system in accordance with Lateral Detail LD-6. The District must approve the design of the system, and the District reserves the right to prohibit the installation of a residential sewage pump system. When installation of a residential sewage pump system is approved, the following general requirements must be met:

Installation of the sewer ejector pump, electrical work, holding tank and alarm must: a) meet the codes and regulations of the building department of jurisdiction issuing the building permit; and b) be inspected by an inspector from said building department.

The discharge pipe from the building outlet to the sewage pump must be gravity flow and be equipped with a blow-off cleanout. The pressurized discharge line from the holding tank must be

equipped with a check valve as close as possible to the holding tank, followed by a gate valve. The pressurized discharge line must be installed for the shortest distance feasible, at which point the pressurized discharge line must be converted to gravity flow using a wye, and a cleanout must be installed on the gravity flow portion of the wye. A pressurized discharge line will not be permitted to connect to the main sewer unless no other alternative is possible AND, in the opinion of the District, the main sewer can facilitate the pressurized connection.

All gravity and pressure discharge lines must be inspected by a District Inspector before being covered.

3-10 Connections to Sewer Mains.

A. Connections of lateral sewers to sewer mains shall be per Table 1: PRIVATE LATERAL SEWER PIPE MATERIALS LIST, as follows:

Sewer Main Pipe Material	Connection Type
VCP, PVC, DIP, CIP or ACP	New Wye Fitting
HDPE	Electrofusion Saddle
Existing Pipe Lined w/CIPP	Tap Connection

1. The Contractor shall cut and remove a portion of the existing main as required. Install a new wye fitting, spools of pipe, and adjustable repair couplings for connection to the existing main (perform a pipeline spot repair with a new wye fitting).
  - a. If the new wye fitting is within 12 inches of an existing joint on the main line, the installation and replacement of the main shall extend beyond the joint (i.e., the joint shall be cut and removed). The new pipe material shall match the existing main, unless otherwise noted.
2. Tap connections (in lieu of a new wye fitting) may be used for connections to existing sewer mains with an inside diameter of 10 inches or larger. Tap connections shall be per DETAIL “Tap Connections to Existing Sewer Mains”.
3. Electrofusion saddles shall be per DETAIL “HDPE Couplings”.
4. Remove host pipe and connect tap connections to existing CIPP liner. Tap connection shall be per DETAIL “Tap Connections to Existing Sewer Mains”.

3-11 Pipebursting Rehabilitation of Laterals

Pipebursting rehabilitation of lateral sewers with a minimum of three (3) feet of cover within street right of ways may be performed with District approval.

The District may reject the use of pipebursting method for rehabilitation of lateral sewers based on the pre-installation CCTV or on site conditions. If lateral has sag(s) or bend(s), it will not be eligible for pipebursting.

The trenchless pipe replacement shall utilize High Density Polyethylene (HDPE) Pipe with a DR of 17 as the carrier pipe and a minimum size of 4" ID (4.5" OD).

Pipes shall be pipeburst using a method that will not cause undue vibration or impact in the ground around the pipe or damage adjacent utilities.

Any obstruction, blockage, or bend encountered, shall be dug up and removed so the pipebursting can be completed without changing pipe material. Whatever portion of the lateral cannot be pipeburst shall be replaced by direct burial.

Contractor shall provide air gaps between existing utilities, repair surface upheaval, and repair sags.

Contractor shall televise lateral after replacement and submit to the District.

### 3-12 Cured-in-Place (CIPP) Rehabilitation of Laterals

CIPP rehabilitation of lateral sewers may be performed only upon prior approval by the District and if a special condition exists, CIPP materials shall be approved by the District. The Contractor shall provide written certificates from the lining manufacturer. Prior to water being discharged into the sewer system, Contractor shall obtain a permit from the wastewater treatment authority (LGVSD or CMSA). Contractor shall televise lateral with District Inspector's presence and submit the recorded video to the District for its file.

### 3-13 Closed Circuit Television Inspections (CCTV)

All CCTV inspections of the inside of lateral pipes must be performed by a licensed plumber or PACP certified inspector. CCTV inspections submitted to the District for review shall include a .pdf log on a DVD or USB memory stick and a written inspection report, listing all pipe events, defects, sags, lateral connection locations including quadrant position, infiltration points and other conditions, etc., listed on a footage basis. The CCTV report and log shall be in accordance with National Association of Sewer Service Companies (NASSCO) Pipeline Assessment Standards.

3-14 Old Lateral sewers. A new structure or major remodel is not permitted to connect to an old lateral sewer unless the old lateral sewer is tested in the presence of a District Inspector and found to meet all current District requirements, including installation of a backwater prevention device. All costs for examination and testing must be paid by the property owner. A sewer connection permit is required for the new structure and said permit will only be issued after: a) the building department of jurisdiction issues the building permit; and b) payment of applicable fees to the District.

3-15 Abandoned or Unused Lateral sewers. When abandoning lateral sewers or there are unused lateral sewers connected to the main sewer, including lateral sewers from structures that are demolished, the connection to the main must be dug out, and the wye, tee, or connection area must be cut away and spliced with a solid piece of pipe of the same size and dimension, i.e. plugged off. Plugging off must be done in the presence of a District Inspector.

**Comment [BD1]:** DT50: May need to be revised to reflect new ordinance. Maybe we can just add a sentence to refer to the Ordinance, depending on the ordinance.

The lateral sewer to be abandoned shall be either completely removed, or abandoned in place and completely filled with controlled low strength material (CLSM) or low density cellular concrete (LDCC).

3-16 Existing Septic Tanks. Septic tanks are under the jurisdiction of the County of Marin Environmental Health Department. The Health Department must be notified when a septic tank is abandoned or encountered during installation of a lateral sewer. The District's requirements are: a) all building plumbing outlets must connect to the lateral sewer and completely bypass the septic tank; and b) the septic tank must be abandoned following regulations of the California Plumbing Code and the County of Marin Environmental Health Department.

Septic tanks must be abandoned if the nearest building is less than 400 feet from the District main.

#### **Section 4. Construction**

4-01 Location of Lateral Stub. It is the responsibility of the property owner or his contractor to locate and uncover the lateral stub or wye installed to serve the property. When the lateral stub or wye cannot be located, the lateral sewer must be connected to the main sewer at a location designated by the District at the expense of the property owner as required in Section 3-10 of this Specification. The District does not guarantee the presence or location of lateral stubs or wyes.

4-02 Bypass Pumping. When performing work on lateral sewers, the Contractor shall bypass wastewater around the work area or shall arrange with the Property Owner to temporarily shut down the lateral sewer. The Contractor shall ensure that no wastewater is discharged from the lateral sewer to the excavation.

4-03 Laying Pipe. Lateral sewers must be laid by the shortest route from the building plumbing outlet to connect to the main sewer and must be perpendicular to the public right-of-way when possible. All pipes must be laid to line and grade. Each length of pipe must be laid on a firm bed as detailed in Lateral Detail LD-4 and must have full bearing for its entire length between bells. When applicable, an adequate bell hole must be dug at the end of each pipe length for making the joint. Blocking under the lateral sewer will not be permitted. The inside edge of any cut pipe must be beveled, and both bell and spigot must be marked for proper inspection and cleaned before the joint is made. Care must be taken to prevent foreign materials from entering the pipe. Water must be pumped from the trench while the pipes are laid and the joints made. Backfill must be carefully and uniformly placed around the pipe, with no rocks or clods touching the pipe. In rocky areas, imported bedding material may be required. Pipe must not be covered until inspected by a District Inspector.

4-04 Inspections. Prior to backfilling, lateral sewer installations and modifications must be inspected by a District Inspector. When required, tests for watertightness must be done in the presence of a District Inspector. Connections to the main sewer must be done in the presence of a District Inspector. It is the responsibility of the Contractor to arrange for any necessary



District inspections. Inspections must be scheduled with the District giving three (3) working days advance notice. Inspections are not made on Saturdays, Sundays, or holidays. Work performed without inspection will be required to be exposed and tested in the presence of the District Inspector at the Property Owner or Contractor's expense. Contractor shall set-up and be ready for testing/inspection upon the District Inspector's arrival. If Contractor is not ready and will need to reschedule, Contractor is subject to Inspection and Re-inspection Fees.

4-05 Trenches Lateral sewers - Excavation and Backfilling. Trenches for lateral sewers within public streets must be excavated and backfilled and the pavement restored in strict accordance with the laws, ordinances, and regulations of the State of California, County of Marin, City of San Rafael and/or agency having jurisdiction over said street. The District, City and/or County reserves the right to require compaction tests on trench backfill by a soils engineer. The cost of compaction tests must be paid by the contractor or property owner.

4-06 Clay Plugs. Impervious clay trench plugs must be constructed in the pipe zone backfill at intervals of approximately two hundred (200) feet, or as otherwise directed by a District Inspector. Impervious clay trench plugs must: a) consist of dense clay material free of rocks and vegetation, and b) be moisture-conditioned and mechanically compacted to the same density as the adjoining backfill material.

4-07 Trenches in Slopes. Trenches in ground sloping greater than fifty percent (50%) from the horizontal must be protected from erosion by placing rip-rap in cement mortar or concrete laid flush with the slope over the backfilled trench, or other protective measures must be taken as directed by a soils engineer and approved by the District. Drains which are two inches in diameter must be installed in the concrete covering at five-foot intervals along the trench line.

For trenches in slopes less than fifty percent (50%) the District may require the use of redwood trench dams or other types of erosion control.

4-08 Testing of Gravity Sewers. Lateral sewers must be tested by an Air test at a minimum of 4 psi for a minimum period of five (5) minutes. If the pressure remains constant during the test period, the line has passed. If the pressure drops during the test time, the line has failed the test.

- a. Hydrostatic testing of gravity pipelines may be performed in lieu of air testing if approved by the District. Fill segment with water to an elevation four (4) feet above the top of pipe at the upstream end of the test section, or four (4) feet above the existing groundwater elevation, whichever is greater. If the water level is maintained for a minimum of fifteen (15) minutes, the line has passed.

4-09 Testing of Pressure Sewers. Pressure sewers must be tested under a pressure of one hundred fifty percent (150%) of maximum design operating pressure measured at the lowest point of the pipeline section being tested, or 50 psi, whichever is greater. The leakage shall be zero for a minimum test period of fifteen minutes.

4-10 Special Conditions. When encountering special conditions which are not covered by the Specifications herein or the District Standard Specifications and/or Code, a District

Inspector and/or the District Engineer will direct the contractor or property owner in the required procedures.

References:

Table 1 – Private Lateral Sewer Pipe Materials List

## **Section 5. Details**

Lateral Detail 1 – 4” Lateral Sewer Detail

Lateral Detail 1.1 – 6” or 8” Lateral Sewer Detail

Lateral Detail 2 – Backwater Check Valve and Shutoff System

Lateral Detail 3 – Residential Sewer Pumping Station

Lateral Detail 4 – Typical Trench Section

Lateral Detail 5 – Steep Slope Lateral Installation

Lateral Detail 6 – Residential Sewerage Pumping System

**SAN RAFAEL SANITATION DISTRICT  
LAS GALLINAS VALLEY SANITARY DISTRICT**

**TABLE 1  
PRIVATE LATERAL SEWER PIPE MATERIALS LIST  
(Specific Use Subject to District Approval)**

Pipe Specifications	Can Be Used for New Gravity Sewers	Can Be Used for Ejector Pump Discharge Pipelines <sup>4</sup>
Vitrified Clay Pipe (No Hub), VCP	No	No
Acrylonitrile Butadiene Styrene Pipe, ABS	No	No
Cast Iron Soil Pipe (No Hub), CIP	No	No
Ductile Iron Pipe w/Shear Band Joints, DIP	Yes <sup>2</sup>	No
PVC ASTM D-2241, SDR=26 Pipe <sup>4</sup>	No	No
PVC AWWA C-900, min SDR=21 Pipe	Yes <sup>2</sup>	Yes <sup>2</sup>
PVC Sch 40 Pipe	No	No
PVC Sch 80 Pipe	No	Yes <sup>2</sup>
Polyethylene (HDPE), min SDR=17 Pipe <sup>3</sup>	Yes <sup>1</sup>	Yes <sup>1</sup>

- <sup>1</sup> Requires minimum 3-foot cover with imported bedding and pipe zone backfill.
- <sup>2</sup> Requires minimum 18-inch cover on private property with imported bedding and pipe zone backfill or shaded with select native material containing rocks no larger than 1" sieve size.
- <sup>3</sup> HDPE Pipe shall be fused. Internal beads from fusing action must be removed (de-beaded). No rubber shear bands. All fittings must have the bead removed.
- <sup>4</sup> Pressure pipe applications require minimum pressure rating of 50 psi, or as required by the California Plumbing Code, whichever is greater. Sewer pipes less than 10 feet from water mains requires 150 psi for all sewers.

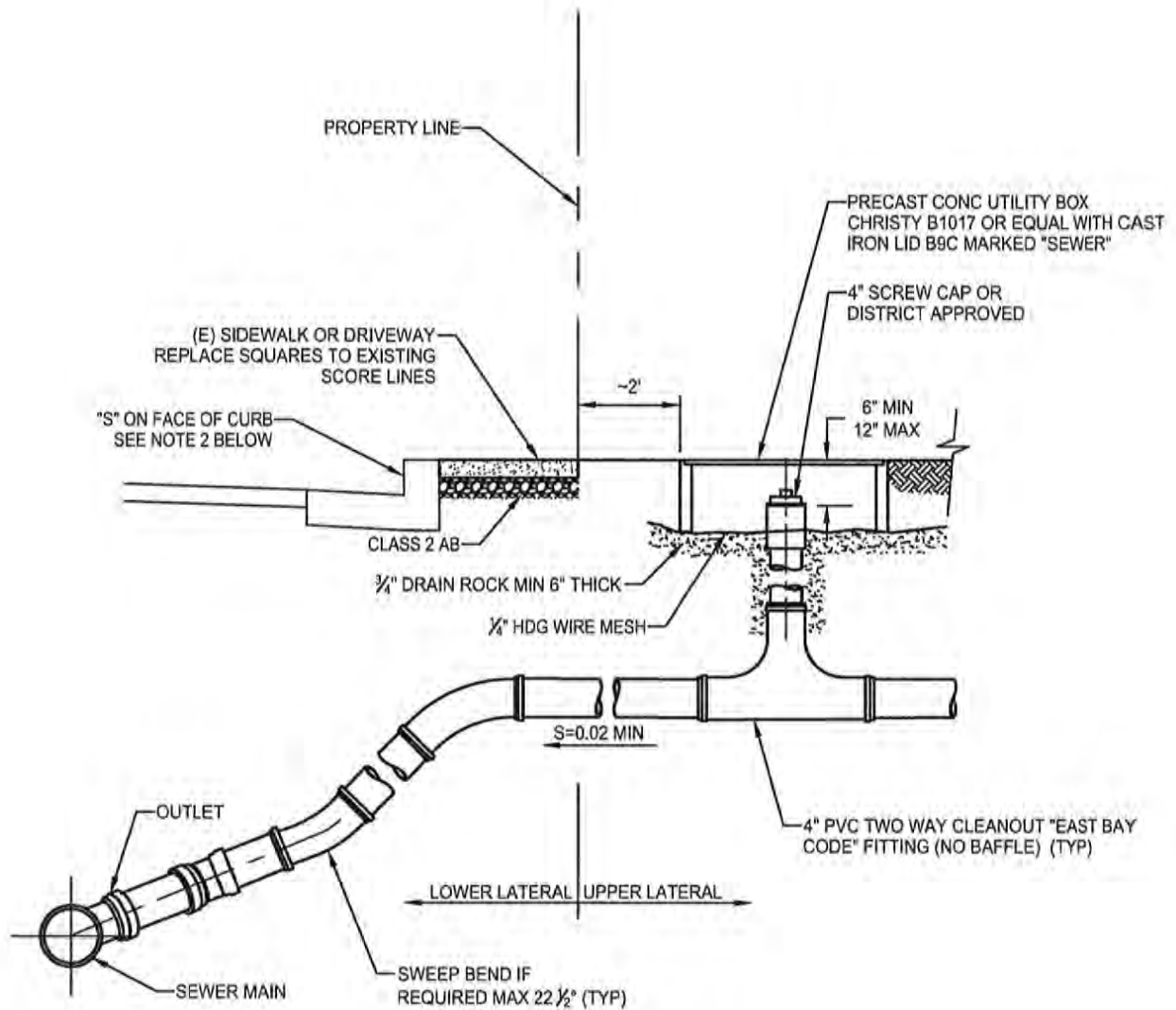

**NOTES:**

1. WHEN A LATERAL SEWER IS INSTALLED IN ADVANCE OF THE BUILDING SEWER, IT SHALL BE TERMINATED AT OR NEAR THE PROPERTY LINE. THE END OF THE LATERAL SHALL BE MARKED WITH A 4" X 4" REDWOOD STAKE, PAINTED GREEN, FROM THE TOP OF THE PIPE TO A MINIMUM OF 6" ABOVE THE FINISHED GROUND SURFACE.
2. WHERE CONCRETE CURBS AND GUTTERS EXIST OR ARE TO BE A PART OF AN IMPROVEMENT, EACH SIDE SEWER SHALL BE PERMANENTLY LOCATED BY IMPRINTING OR CHISELING AN "S" (3" SIZE) IN THE FACE OF THE CURB VERTICALLY ABOVE THE SEWER PIPE.
3. BACKFILL SHALL NOT BE PLACED UNTIL PIPE INSTALLATION HAS BEEN INSPECTED AND APPROVED BY THE DISTRICT. PIPE BEDDING 3" AROUND PIPE ON PRIVATE PROPERTY.
4. BACKWATER PREVENTION DEVICE (CONTRA COSTA VALVE OR DISTRICT APPROVED) SHALL BE INSTALLED ON A 4" MINIMUM RISER PIPE NOT MORE THAN 2' FROM BUILDING WALL, PER STANDARD DETAIL LD 2.
5. LATERAL TRENCHES IN AREA OF PUBLIC STREET CURB, GUTTER AND SIDEWALK SHALL BE COMPACTED THE SAME AS TYPICAL TRENCH DETAIL LD 4. AREAS AROUND NEW CONCRETE CLEAN-OUT BOXES SHALL BE SOILS TESTED TO VERIFY 95% COMPACTION.
6. SLOPES LESS THAN 0.02 MUST BE APPROVED BY DISTRICT ENGINEER.

DRAFT

**LAS GALLINAS VALLEY  
SANITARY DISTRICT**

**4" LATERAL SEWER DETAIL**

2019

PLOTTED ON 7/17/2019  
3:24 PM

LD 1

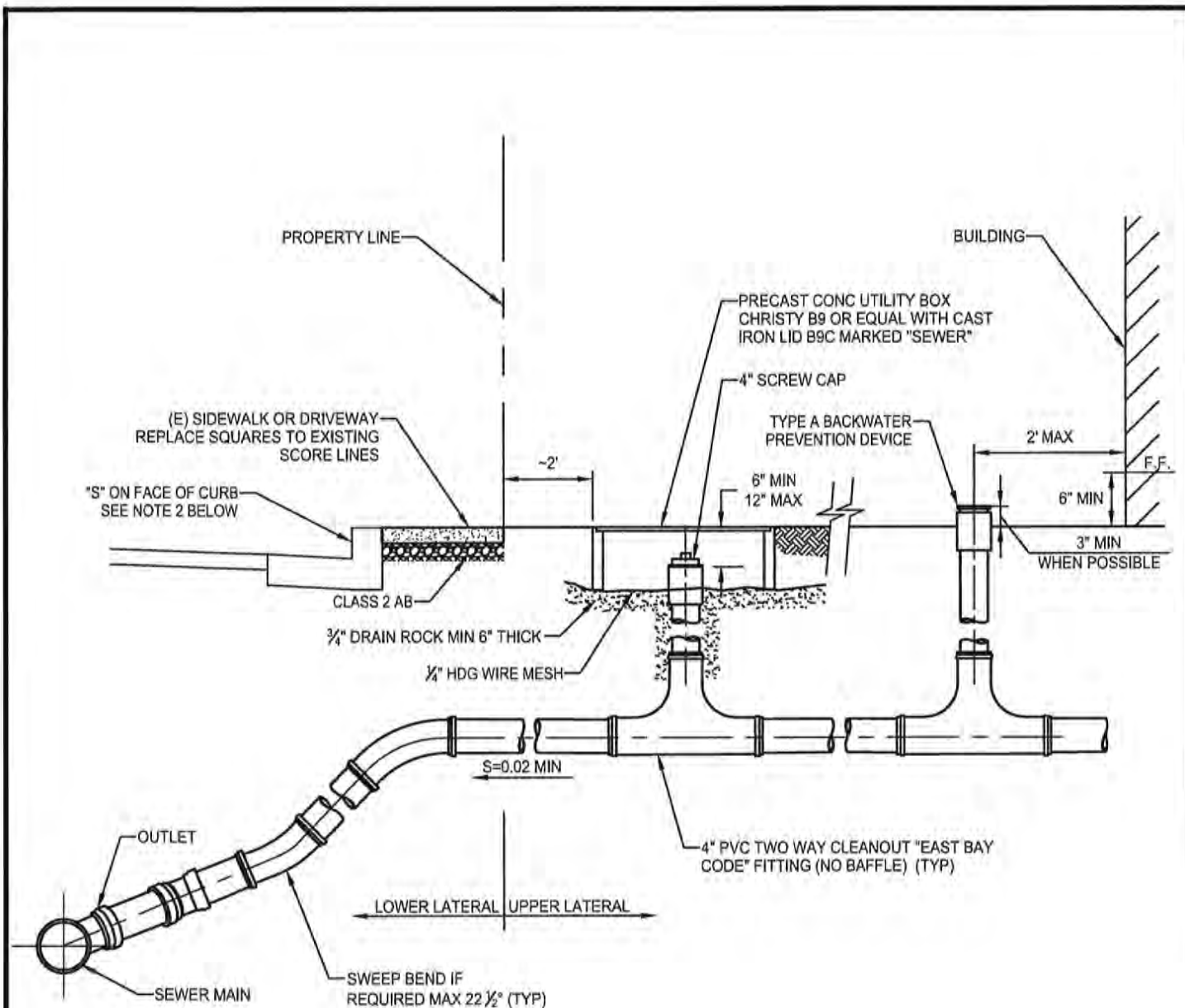

**NOTES:**

1. WHEN A LATERAL SEWER IS INSTALLED IN ADVANCE OF THE BUILDING SEWER, IT SHALL BE TERMINATED AT OR NEAR THE PROPERTY LINE. THE END OF THE LATERAL SHALL BE MARKED WITH A 4" X 4" REDWOOD STAKE, PAINTED GREEN, FROM THE TOP OF THE PIPE TO A MINIMUM OF 6" ABOVE THE FINISHED GROUND SURFACE.
2. WHERE CONCRETE CURBS AND GUTTERS EXIST OR ARE TO BE A PART OF AN IMPROVEMENT, EACH SIDE SEWER SHALL BE PERMANENTLY LOCATED BY IMPRINTING OR CHISELING AN "S" ( 3" SIZE) IN THE FACE OF THE CURB VERTICALLY ABOVE THE SEWER PIPE.
3. BACKFILL SHALL NOT BE PLACED UNTIL PIPE INSTALLATION HAS BEEN INSPECTED AND APPROVED BY THE DISTRICT. PIPE BEDDING 3" AROUND PIPE ON PRIVATE PROPERTY.
4. BACKWATER PREVENTION DEVICE (CONTRA COSTA VALVE OR DISTRICT APPROVED) SHALL BE INSTALLED ON A 4" MINIMUM RISER PIPE NOT MORE THAN 2' FROM BUILDING WALL, PER STANDARD DETAIL LD 2.
5. LATERAL TRENCHES IN AREA OF PUBLIC STREET CURB, GUTTER AND SIDEWALK SHALL BE COMPACTED THE SAME AS TYPICAL TRENCH DETAIL LD 4. AREAS AROUND NEW CONCRETE CLEAN-OUT BOXES SHALL BE SOILS TESTED TO VERIFY 95% COMPACTION.
6. SLOPES LESS THAN 0.02 MUST BE APPROVED BY DISTRICT ENGINEER.

DRAFT

**LAS GALLINAS VALLEY  
SANITARY DISTRICT**

**4" LATERAL SEWER DETAIL  
OVER 90 LF LONG**

**2019**

PLOTTED ON 7/17/2019  
3:24 PM

**LD 1.1**

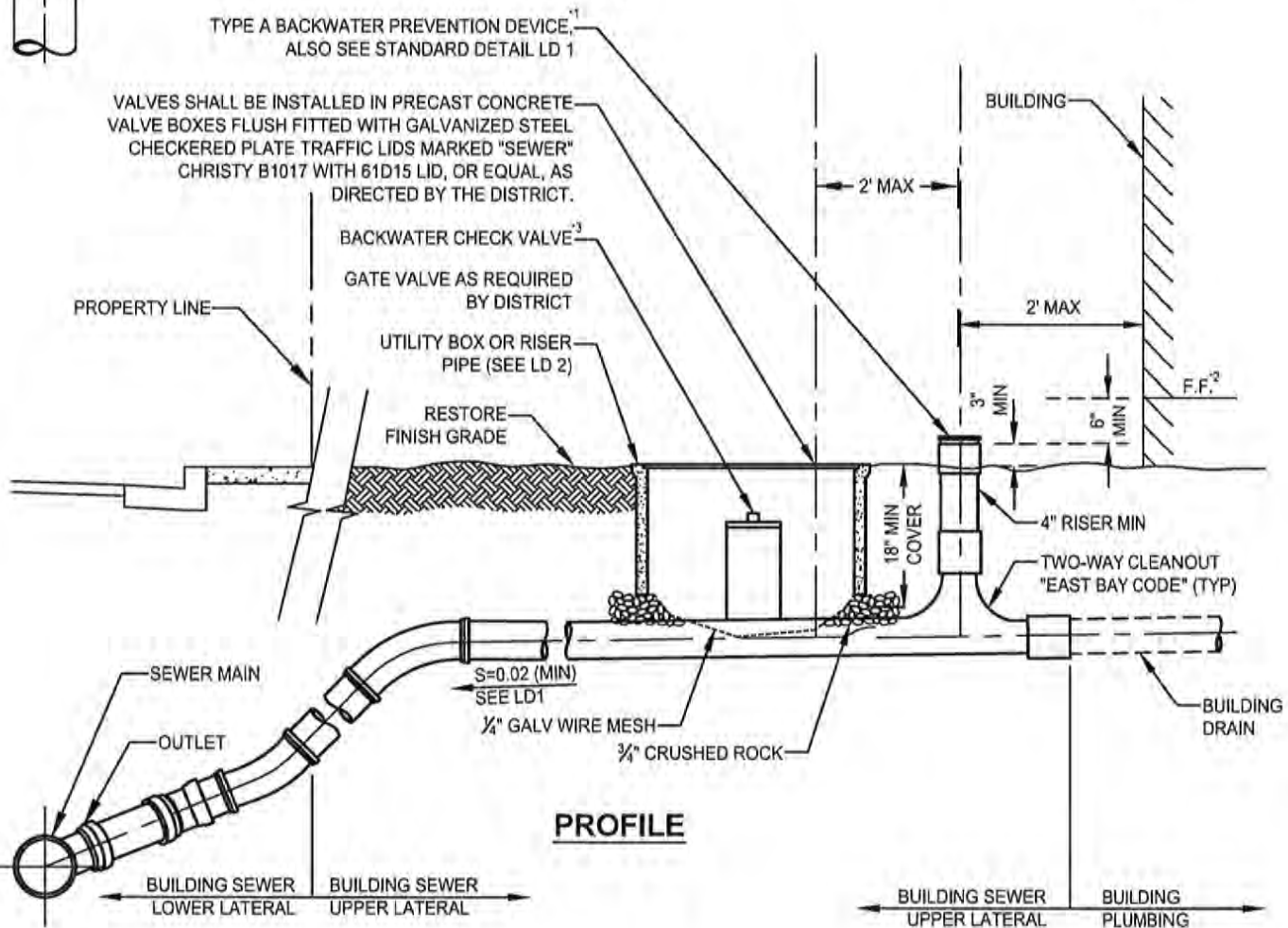
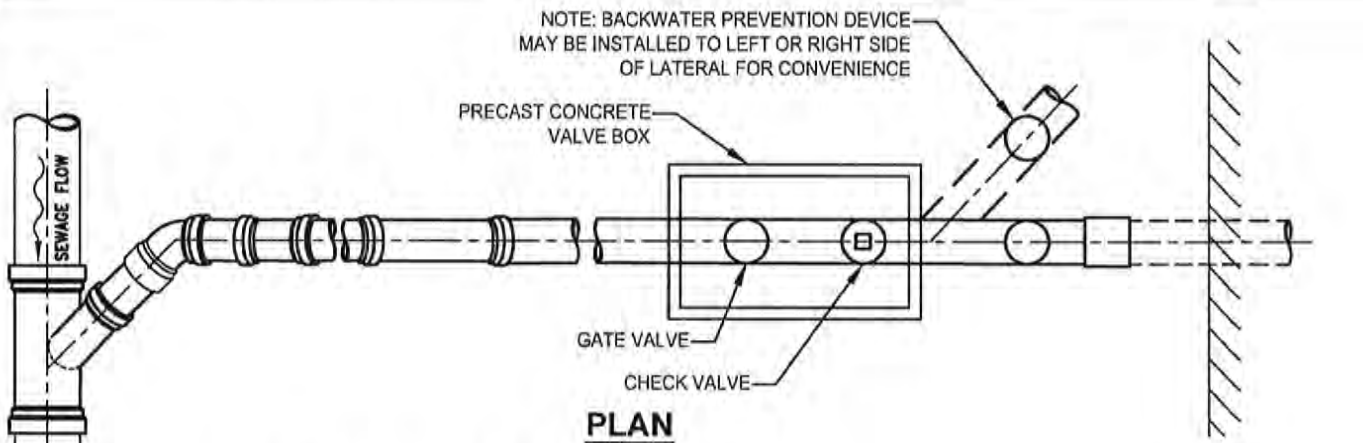

**\*NOTE:**

1. SHALL BE A CONTRA COSTA VALVE OR DISTRICT APPROVED, WHICH OPENS WHEN WATER PRESSURE BUILDS BENEATH IT TO OFFER PROTECTION TO THE HOME FROM SEWER BACKUPS INTO THE STRUCTURE.
2. FINISHED FLOOR (F.F.) MUST BE MIN 6" ABOVE THE BACKWATER PREVENTION DEVICE.
3. THE BACKWATER CHECK VALVE MAY BE REQUIRED WHEN THE F.F. IS NOT AT LEAST 6" ABOVE THE UPSTREAM MANHOLE OR RODHOLE ON THE DISTRICT MAIN.

DRAFT

**LAS GALLINAS VALLEY  
SANITARY DISTRICT**

6" OR 8" LATERAL SEWER DETAIL

2019

PLOTTED ON 7/17/2019  
3:24 PM

LD 2

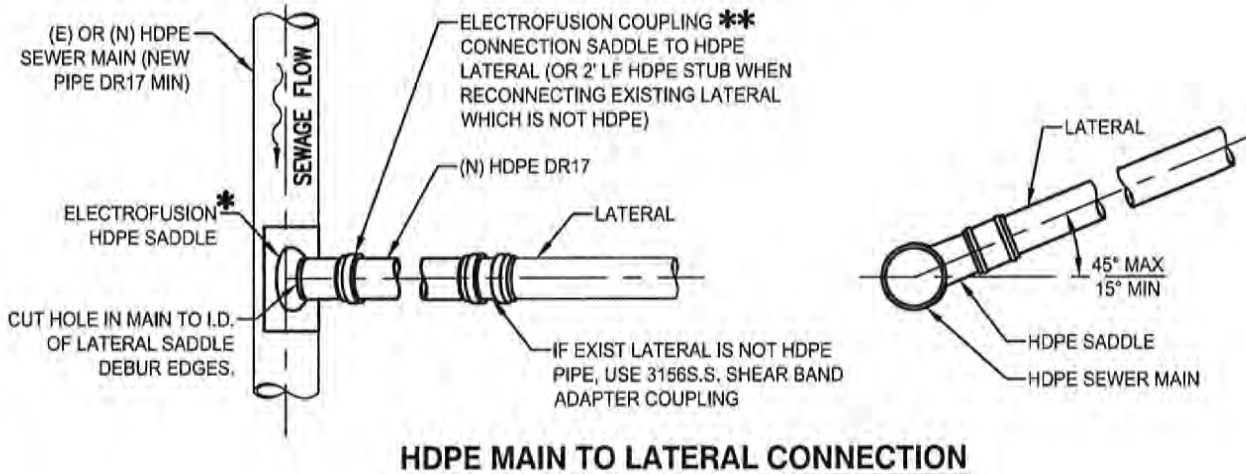
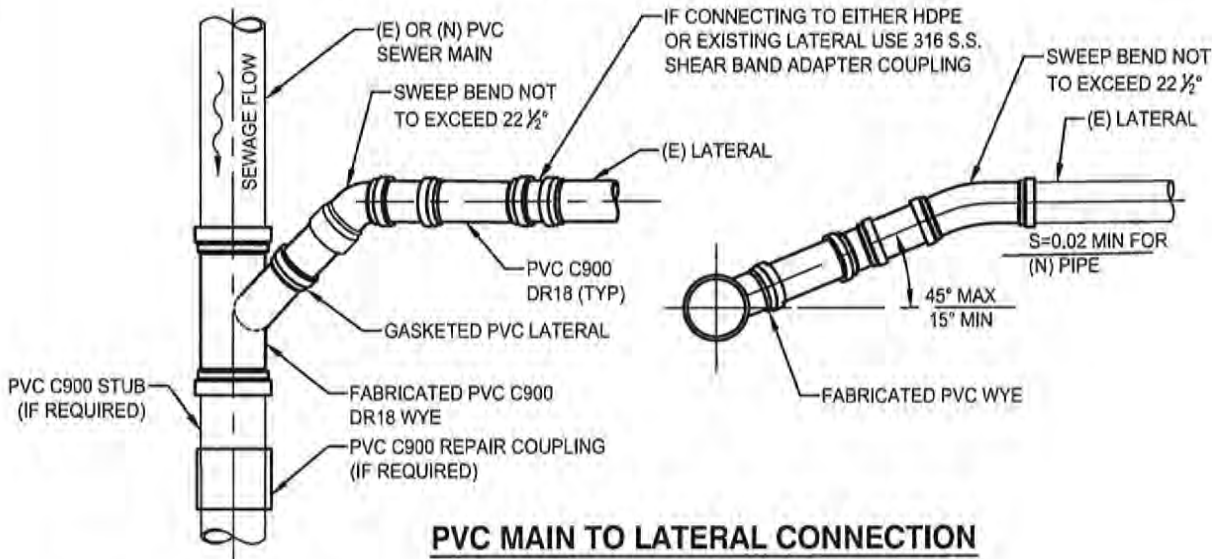
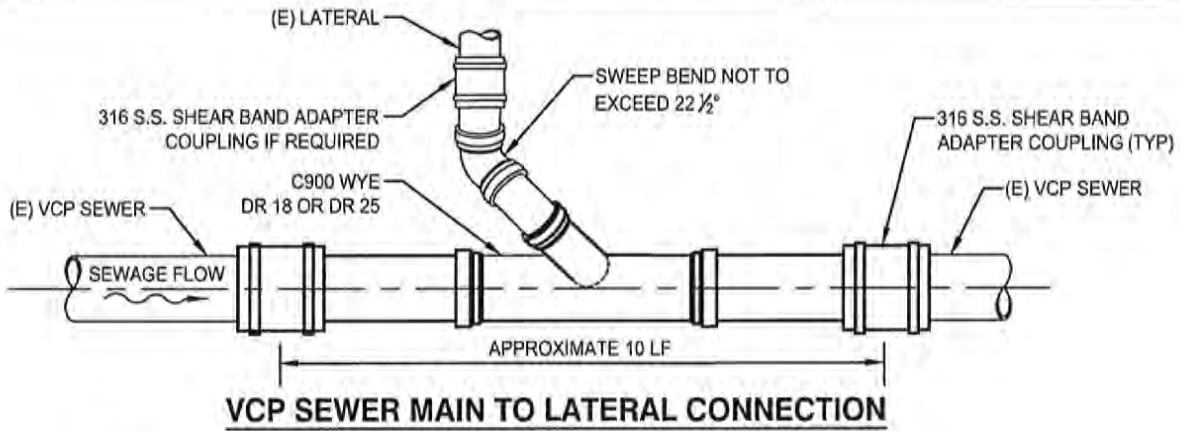

- \* CENTRAL, FRIATEC. OR APPROVED EQUAL WITH PLAIN END COUPLING
- \*\* LATERAL CONNECTION CENTRAL, FRIATEC OR APPROVED EQUAL

# LAS GALLINAS VALLEY SANITATION DISTRICT

## LATERAL CONNECTION TO SEWER MAIN

2019

PLOTTED ON 7/17/2019  
3:25 PM

LD 3

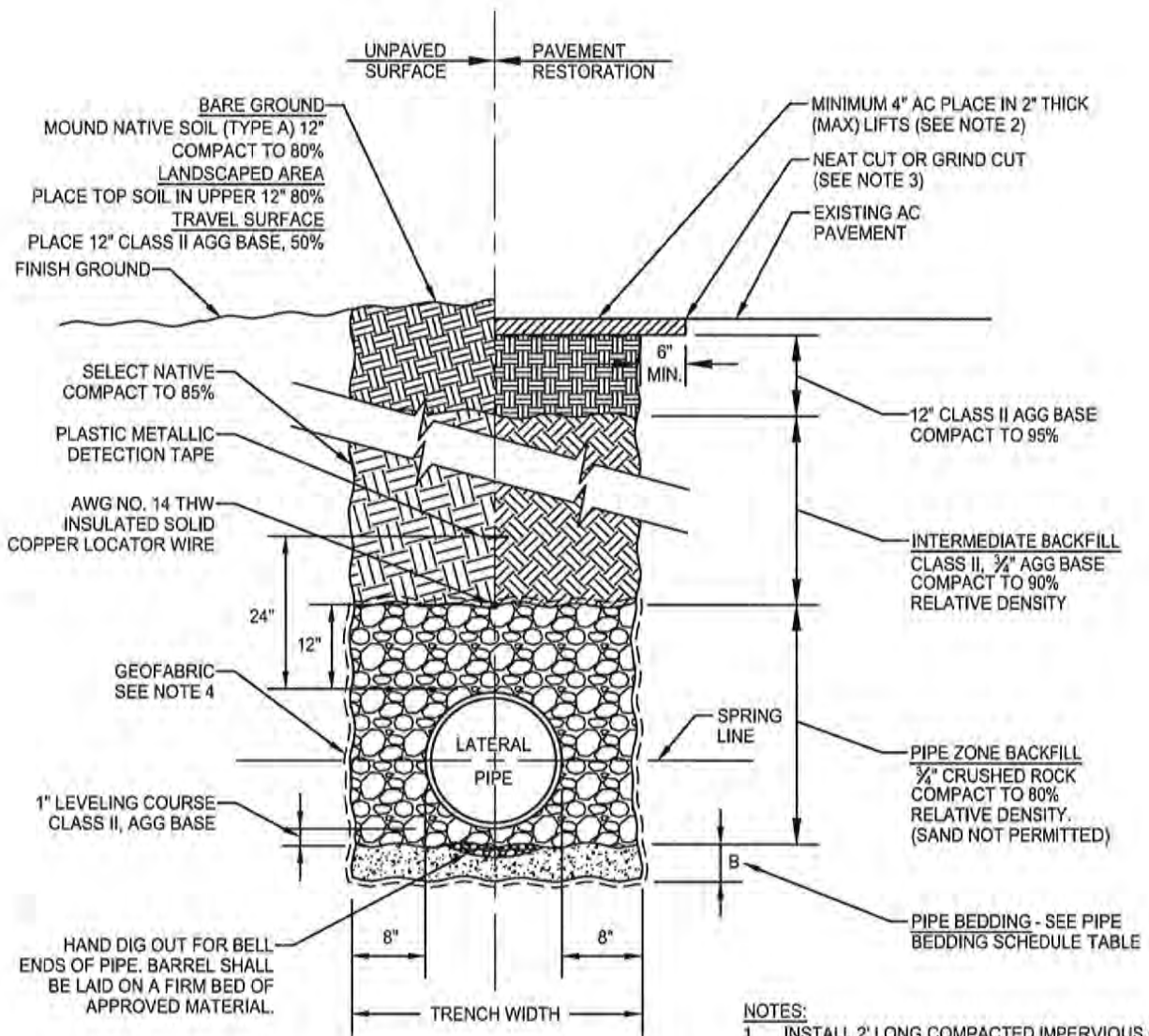

## PIPE TRENCH SECTION DETAIL

### NOTES:

1. INSTALL 2' LONG COMPACTED IMPERVIOUS CLAY OR CDF PLUGS IN PIPE ZONE BACKFILL AND PIPE BEDDING AT 100' INTERVALS, OR AS DIRECTED BY THE CITY.
2. ASPHALT THICKNESS SHALL CONFORM TO THE REQUIREMENTS OF THE AGENCY WITH JURISDICTION OVER STREET.
3. CONSULT LOCAL JURISDICTION FOR ASPHALT CUTTING REQUIREMENTS. (ENCROACHMENT PERMITS MAY BE REQUIRED)
4. INSTALL WHEN DIRECTED BY DISTRICT ENGINEER. INSTALL GEOFABRIC BACK FILL WRAP. **DRAFT**

PIPE BEDDING SCHEDULE		
TRENCH MATERIAL	BEDDING DEPTH - B	BEDDING MATERIAL
SOIL - DRY	6"	¾" CRUSHED ROCK
SOIL WITH WATER	12"	1 ½" CRUSHED ROCK
ROCK OR HARD PAN - DRY/WET	6"	¾" CRUSHED ROCK
BAY MUD	12"	1 ½" CRUSHED ROCK (GEOFABRIC WRAP)

**LAS GALLINAS VALLEY  
SANITARY DISTRICTS**

TYPICAL TRENCH SECTION

2016

PLOTTED ON 7/17/2019  
3:25 PM

LD 4



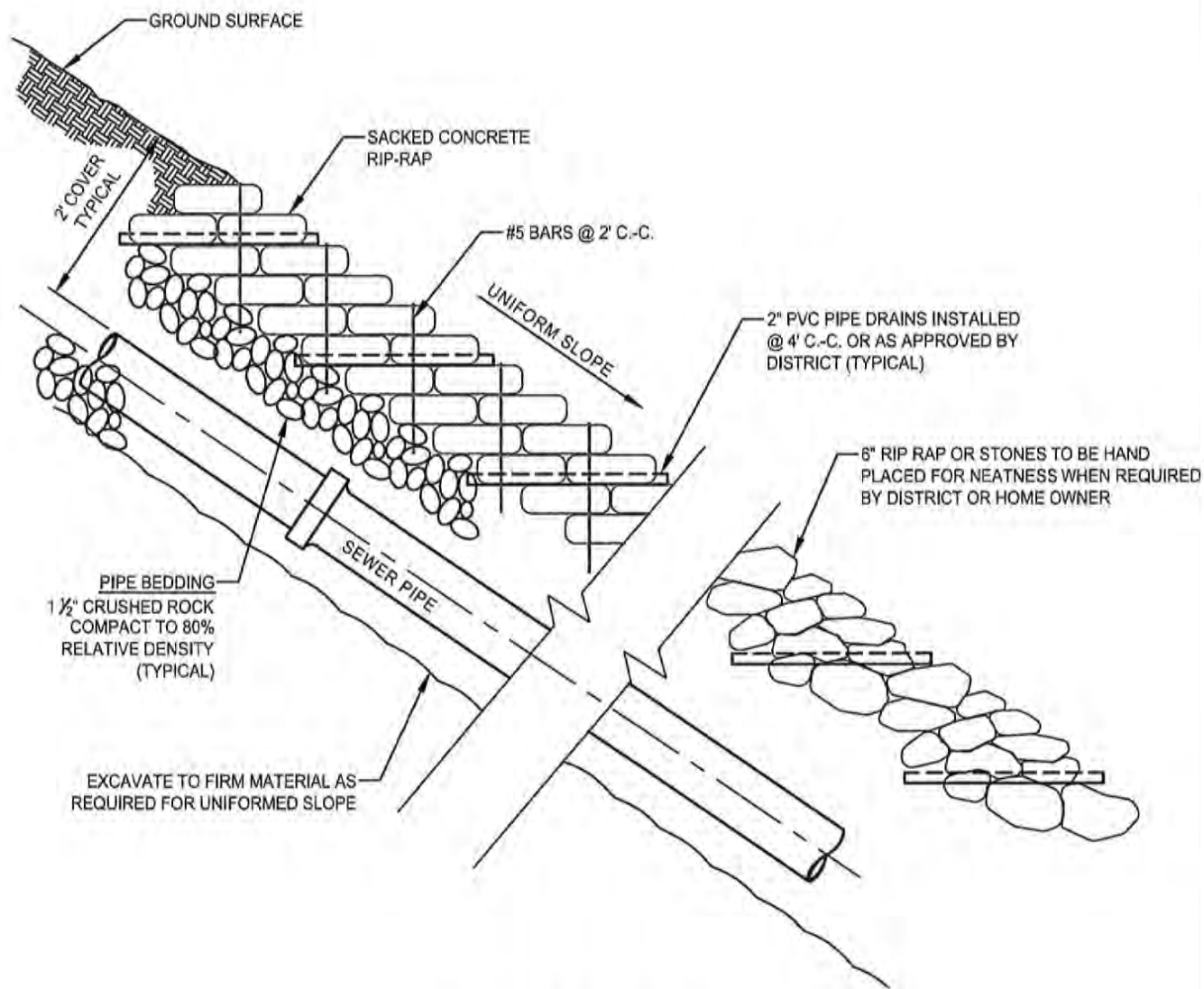

**ELEVATION**

**NOTES:**

1. CHECK BOARDS TO BE PLACED ON ALL SLOPES GREATER THAN 50% OR WHERE REQUIRED BY THE CITY.
2. ALL SLOPES 50% OR GREATER SHALL HAVE CLASS 150 C.I. (MIN) OR C-900 DR18 BELL & SPIGOT PIPE, OR PIPE APPROVED BY THE CITY ENGINEER.
3. SEEDED LANDSCAPE AND EROSION CONTROL DETAIL MUST BE APPROVED BY DISTRICT ENGINEER.

**LAS GALLINAS VALLEY  
SANITATION DISTRICT**

**LATERAL CONNECTION  
TO SEWER MAIN**

**2019**

PLOTTED ON 7/17/2019  
3:25 PM

**LD 5**

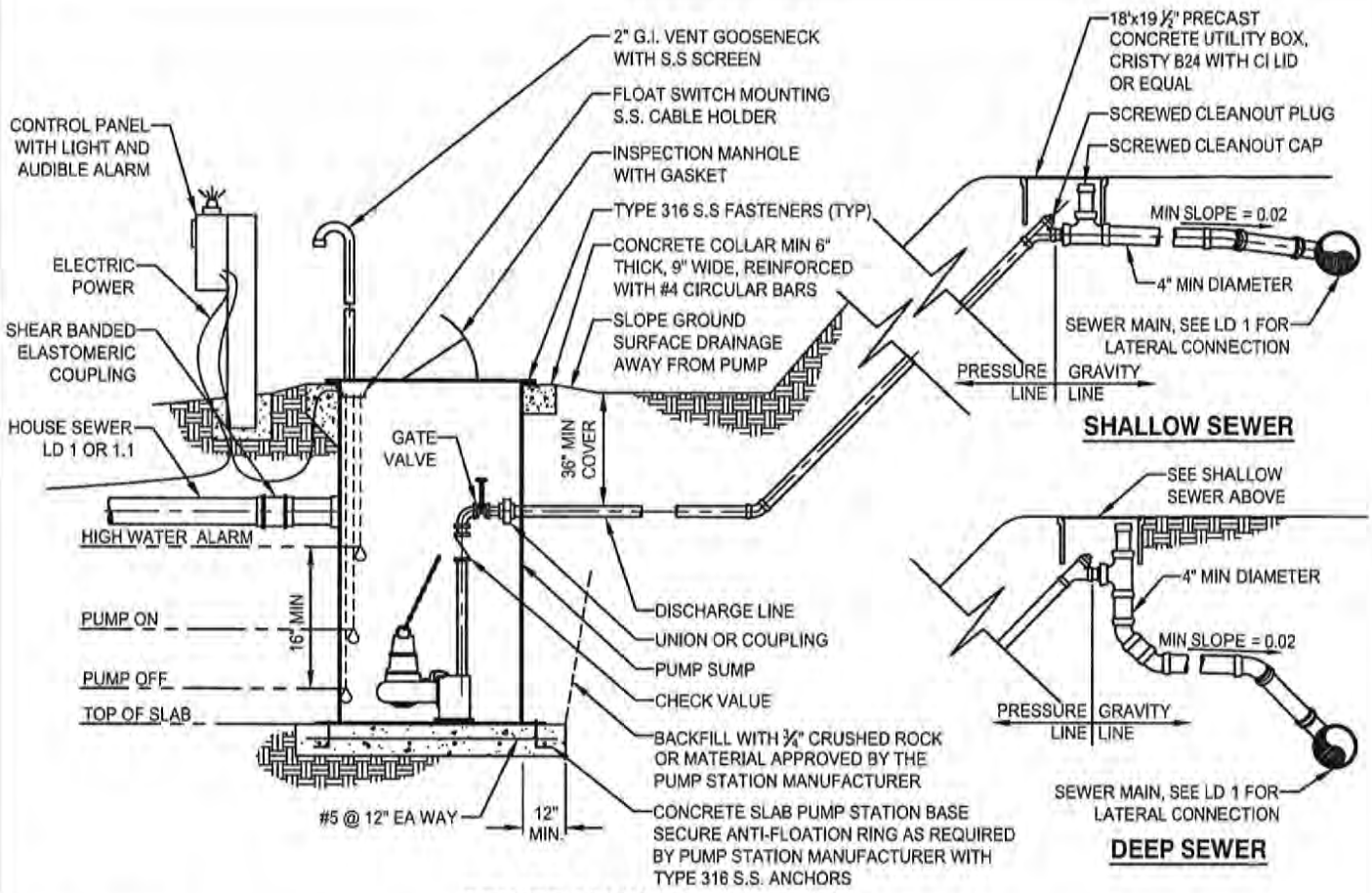

**SEWER MAIN CONNECTION**

N.T.S.

**GENERAL NOTES:**

THE MINIMUM REQUIREMENTS FOR A RESIDENTIAL SEWAGE PUMPING SYSTEM CONNECTING A SINGLE RESIDENCE OR EQUIVALENT TO THE DISTRICT'S SYSTEM ARE SPECIFIED BELOW. THE DISTRICT ACCEPTS NO RESPONSIBILITY FOR THE DESIGN, OPERATION OR MAINTENANCE OF SUCH PRIVATELY OWNED AND OPERATED SYSTEMS. ALL WORK SHALL COMPLY WITH THE UNIFORM PLUMBING AND BUILDING CODES.

**MANUFACTURERS:**

ALL EQUIPMENT AND ACCESSORIES SHALL BE INDUSTRY STANDARD MANUFACTURED ITEMS AND THOSE COMING IN DIRECT CONTACT WITH SEWAGE SHALL BE SPECIFICALLY MANUFACTURED FOR SEWAGE USE.

**PUMPS:**

PUMPS SHALL BE SUBMERSIBLE SOLIDS HANDLING OR GRINDER TYPE SEWAGE PUMPS. ALL PUMP STATIONS FOR RESIDENTIAL OR COMMERCIAL INSTALLATIONS SHALL CONSIST OF DUPLEX EXPLOSION PROOF PUMPS EACH RATED FOR TOTAL LOADING. ALL PUMP MOTORS SHALL BE UL LISTED.

**PUMP SUMP:**

THE PUMP SUMP SHALL BE CONSTRUCTED OUT OF NON-CORROSIVE MATERIAL OF SUITABLE STRENGTH TO WITHSTAND HYDRAULIC AND EARTH LOADS. THE PUMP SUMP SHALL BE A MINIMUM 36" DEEP WITH A MINIMUM CAPACITY OF 200 GALLONS AND SHALL BE PROVIDED WITH A FOUR (4) INCH MINIMUM INLET. IN ANY CASE THE INLET I.D. SHALL BE EQUAL TO OR GREATER THAN THE BUILDING PLUMBING STUB. THE TOP OF THE PUMP SUMP SHALL BE SECURELY ANCHORED TO THE PUMP SUMP BY BOLTS, AND ALL JOINTS BETWEEN THE COMPONENT PARTS SHALL BE SEALED WITH A WATERPROOF MASTIC.

**ELECTRIC POWER SERVICE:**

THE POWER REQUIREMENTS SHALL BE AS RECOMMENDED BY PACIFIC GAS AND ELECTRIC COMPANY.

**ELECTRICAL WORK AND CONTROLS:**

ALL ELECTRICAL WIRING AND INSTALLED CABLING, CONDUIT AND CONTROLS SHALL MEET NEC CLASS 1, DIVISION 2 REQUIREMENTS AND CONFORM TO THE REQUIREMENTS OF THE CITY OR COUNTY. THE ELECTRICAL CONTROLS SHALL PROVIDE ADEQUATE PROTECTION FOR MOTOR AND EQUIPMENT. THE ELECTRICAL CONTROL PANEL SHALL MEET NEC AND UL STANDARDS FOR SAFETY. OUTDOOR PANELS SHALL BE WEATHER TIGHT NEMA 4X. INDOOR PANELS SHALL BE NEMA 1.

**FLOAT SWITCH ASSEMBLY AND HIGH-WATER ALARM:**

A VISIBLE RED LIGHT AND AUDIBLE HIGH WATER ALARM SHALL BE PROVIDED. THE HIGH WATER ALARM SHALL BE ACTIVATED BY A DEDICATED FLOAT AND SHALL HAVE BATTERY BACKUP. ALL FLOAT SWITCHES SHALL HAVE GAS-TIGHT MOUNTINGS.

**VENT FOR PUMP SUMP:**

WHERE SYSTEM IS LOCATED WITHIN THE DWELLING, A VENT TWO (2) INCHES OR LARGER SHALL BE PROVIDED. WHERE SYSTEM IS LOCATED OUTSIDE THE DWELLING, A TWO (2) INCH OR LARGER VENT SHALL BE EXTENDED TO A POINT TEN (10) FEET ABOVE THE PUMP SUMP COVER AND FIVE (5) FEET FROM BUILDING FACE MUST EXIT 6" (MIN) ABOVE BUILDING ROOF.

**DISCHARGE LINE:**

THE PRESSURE PORTION OF THE DISCHARGE LINE SHALL INCLUDE A CHECK VALVE, GATE VALVE AND FLEXIBLE COUPLINGS AND SHALL BE A MINIMUM 2" DIAMETER LARGER THAN THE PUMP DISCHARGE. ALL PIPE, VALVES AND COUPLINGS SHALL CONFORM TO THE STANDARD SPECIFICATIONS. THE GRAVITY PORTION OF THE DISCHARGE LINE SHALL BE FOUR (4) INCH MINIMUM DIAMETER PIPE, SHALL MEET THE DISTRICT REQUIREMENT FOR SIDE SEWERS.

DRAFT

**LAS GALLINAS VALLEY  
SANITATION DISTRICT**

**RESIDENTIAL SEWERAGE  
PUMPING STATION**

2019

PLOTTED ON 7/17/2019  
3:25 PM

LD 6

# UTILITY BOXES

All lids shall be marked/labeled "Sewer" as available, unless otherwise noted.

LOCATION	ITEM DESCRIPTION	PRODUCT
<b>Traffic Areas</b> (including all paved areas and driveways)	Cleanout Boxes	Christy B1017
	Backwater Prevention Devices (Type 2)	Christy V12 Box w/ V12-71W grate.
	Backwater Check Valves	Christy B1017
	Box at end of pressure side sewer (for private pump stations)	Christy B1324 w/ steel cover
<b>Non-Traffic Areas</b>	Cleanout Boxes	Christy B09 Box, w/ precast concrete lid
	Backwater Prevention Devices (Type 2)	Christy V09 Box (Christy B09 box w/ V09-71C Grated Cast Iron Lid)
	Box at end of pressure side sewer (for private pump stations)	Christy B16
	Backwater Check Valves	Christy B09 Box, w/ precast concrete lid



**Christy B1017**



**Christy V12 Box w/ V12-71W Grate**



**Christy B09**



**Christy V09**

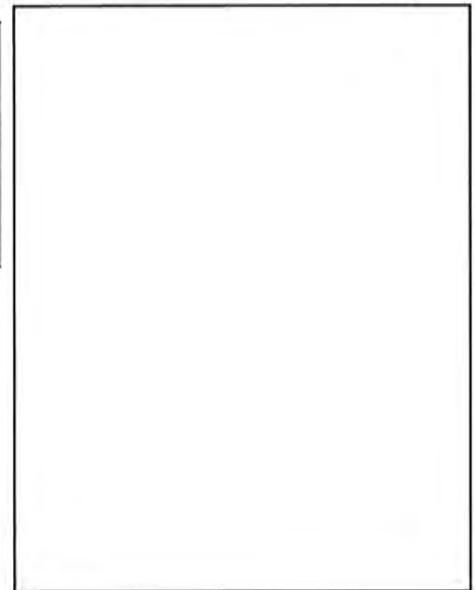

**LAS GALLINAS VALLEY  
SANITARY DISTRICT**

SANITARY DISTRICT  
ACCEPTED MATERIALS

**2019**

PLOTTED ON 7/17/2019  
3:47 PM

**AM 1**

# GEOTEXTTILE FABRIC

Geotextile fabric for laying and wrapping/separating backfill materials shall be manufactured by, or approved equal:

1. Mirafi, 140N
2. US Fabrics, US 135NW
3. Carthdage Mills, FX-45HS

**LAS GALLINAS VALLEY  
SANITARY DISTRICT**

SANITARY DISTRICT  
ACCEPTED MATERIALS

2019

PLOTTED ON 7/17/2019  
3:48 PM

AM 2

# ADJUSTABLE REPAIR COUPLINGS

Use for repairs and alterations to gravity piping at connections of dissimilar materials.

Banded rubber couplings shall have four (4) clamps and metal shear bands.

**All hardware shall be Type 316 Stainless Steel**, including shear bands.

Adjustable repair couplings shall be manufactured by, or approved equal:

1. Fernco, 5000 Series RC Coupling, w/ all type 316 SS hardware
2. Mission Rubber Company, Adjustable Repair Coupling



**Fernco, 5000 Series RC Couplings**



**Mission Rubber Co, Adjustable Repair Coupling**

The following are not allowed:



**Mission® Band Seal**



**Joints® Calder Coupling**



**Anaco – Husky Couplings**



**Fernco, Proflex Coupling**



**Mission Clay Band-Seal (Type 1 or 2)**

**LAS GALLINAS VALLEY  
SANITARY DISTRICT**

SANITARY DISTRICT  
ACCEPTED MATERIALS

2019

PLOTTED ON 7/17/2019  
3:48 PM

AM 3

## HDPE COUPLINGS

Use for field closure of HDPE pipe, as required.

Electrofusion couplings, manufactured by, or approved equal:

1. Ipex USA LLC, Friatec Couplings
2. Central Plastics



**Friatec - Electrofusion Coupling**

**LAS GALLINAS VALLEY  
SANITARY DISTRICT**

SANITARY DISTRICT  
ACCEPTED MATERIALS

2019

PLOTTED ON 7/17/2019  
3:48 PM

AM 4

## Backwater Prevention Devices (BPDs)

Required at every location where sanitary sewer piping exits a building/home to prevent sewage from entering homes and businesses and reroute the spill outside the building.

BPD Type	MANUFACTURER	PRODUCT NAME
<b>Type 1 or "Mushroom" Type</b>	Genplex	Kelly Backwater Device (No-Hub & IPS)
<b>Type 2</b>	Stephens Corp	Sewer Popper™ Model S62-304
	Unlimited Home Solutions LLC (www.unlimitedhomesolutions.com)	Sewer Relief Cap

### Type 1



**Mushroom Type**

### Type 2



**Sewer Popper™ OPD**



**Sewer Relief Cap**

**LAS GALLINAS VALLEY  
SANITARY DISTRICT**

SANITARY DISTRICT  
ACCEPTED MATERIALS

**2019**

PLOTTED ON 7/17/2019  
3:48 PM

**AM 5**

## BACKWATER CHECK VALVES

Backwater check valves shall be extendable type. Manufactured of PVC

Manufactured by the following, or approved equal

1. Rector Seal, Clean Check Backwater Valve
2. Mainline Backflow Products, Adapt-A-Valve Inspector chamber w/ Test-Eze Gate Feature



PVC Extendable Backwater Valve

**LAS GALLINAS VALLEY  
SANITARY DISTRICT**

SANITARY DISTRICT  
ACCEPTED MATERIALS

2019

PLOTTED ON 7/17/2019  
3:48 PM

AM 6



# TAP CONNECTIONS TO EXISTING SEWER MAINS

All connections to new mains shall be with new wye fittings matching the main pipe material, or electrofusion saddles for new HDPE mains.

Tap connections will only be allowed for connection to existing mains 10-inch and larger and will require District approval. However, all new connections to existing mains with an existing CIPP liner shall be with a tap connection (new wye fittings will not be allowed on existing CIPP).

Tap connections shall be "Wye type" were feasible.

EX MAIN PIPE MATERIAL	MAINLINE TAP
VCP, PVC, DIP, Cast Iron, or ACP	Cascade Waterworks MNFR Co, CSWRY Stainless Steel Sewer Saddle –Wye
HDPE	Electrofusion saddles: $\leq 12$ " main wye type, $> 12$ " main may be tee type, manufactured by, or equal: <ul style="list-style-type: none"> <li>• Central Plastics</li> <li>• Industrial Pipe Fittings, LLC - Plasson</li> </ul>
Ex Pipe Lined w/ CIPP	Remove host pipe at connection and install directly to CIPP. <ul style="list-style-type: none"> <li>• Inserta Wye or Inserta Tee</li> <li>• Cascade Waterworks MNFR Co, CSWRY Stainless Steel Sewer Saddle – Wye</li> <li>• LMK Technologies, Lined Main Tap</li> </ul>



Cascade CS WRY



Inserta Wye



Inserta Tee



HDPE – Central Plastics



HDPE – IPF Plasson



LMK, Lined Main Tap

**LAS GALLINAS VALLEY  
SANITARY DISTRICT**

SANITARY DISTRICT  
ACCEPTED MATERIALS

2019

PLOTTED ON 7/17/2019  
3:48 PM

AM 7

# SIDE SEWER FITTINGS

Side sewer fitting material shall match side sewer pipe material, unless otherwise directed or allowed by the District.

Property line cleanouts shall be a two-way or a "Tee" wherever possible. However, a one-way will be allowed. Contractor is advised to discuss with property owner, and the District encourages the use of two-way cleanouts.

SIDE SEWER MATERIAL	SIDE SEWER FITTINGS
<b>PVC C900 DR-18</b>	PVC C900, min DR-18 thickness, bell and spigot. Tee, Wye, 45° fitting, or 90° sweep fittings. White color where feasible. Manufactured by, or equal: <ul style="list-style-type: none"> <li>• Specified Fittings, C900 Gasketed</li> <li>• Multi Fittings, Sewer Brute</li> </ul>
<b>HDPE</b>	HDPE, SDR 17 min thickness. <ul style="list-style-type: none"> <li>• Butt fusion Tee, Wye, 45° fitting, or 90° elbow. Fuse directly to side sewer, or use couplings as required. Manufactured by: Performance Pipe, Agru America, or equal.</li> <li>• Electrofusion tees. Manufactured by Central Plastics, Harrington Corp, or equal.</li> <li>• Electrofusion taps (for cleanout risers). Manufactured by Central Plastics Harrington Corp, or equal.</li> </ul>
<b>SCH 80 PVC</b>	Schedule 80 PVC. Tee, Wye, 45° fitting, or 90° sweep fittings. Solvent welded, threaded, or flanged joints.

## HDPE FITTINGS



**Butt Fusion Tee**



**Butt Fusion Wye**



**Electrofusion Tee**



**Electrofusion Tap**

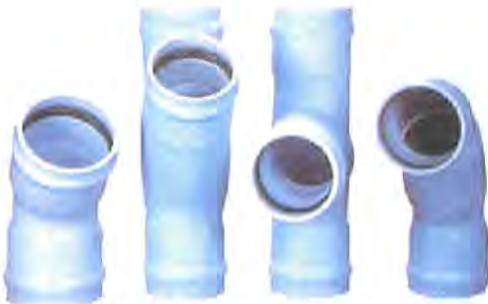

**PVC C900 fittings**



**Schedule 80 PVC fittings**

**LAS GALLINAS VALLEY  
SANITARY DISTRICT**

SANITARY DISTRICT  
ACCEPTED MATERIALS

**2019**

PLOTTED ON 7/17/2019  
3:49 PM

**AM 8**

## Cured-in-Place Pipe (CIPP) Products

### Chemical Grout

For sealing side sewer connection to mains and/or pipe connections to manholes. Manufacturer shall be, or approved Equal

- Avanti, AV-100

### CIPP Main to Side Sewer Seals

For repairing side sewer connection to mains 8-inch or larger where main is in suitable condition, as Determined by the District. Manufactured by, or approved equal:

- Pro Pipe Professional Pipe Services, Top Hat Lateral Seals

### Main to Side Sewer CIPP Connection Liners

For repairing side sewer connection to mains 8-inch or larger where the main is in suitable condition, as Determined by the District. Manufactured by, or approved equal:

- LMK Technologies, T-Liner/Shorty



**Avanti, AV-100**



**Top Hat**

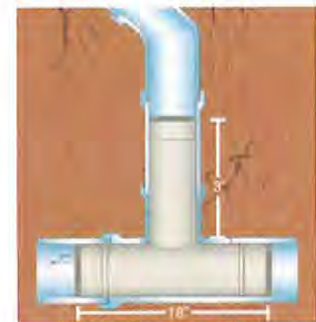

**T-Liner/Shorty**

### CIPP Point Repairs

Use only where approved by the District. Manufacture by, or approved equal:

- LMK Technologies, Mainline Sectional Repair



**LMK Mainline Sectional Repair**

### CIPP for Side Sewers

Use only where approved by the District. Installer must be certified by the manufacturer. CIPP Manufacturer shall be, or approved equal:

- Perma-Liner Industries, LLC
- MAXLINER LLC

**LAS GALLINAS VALLEY  
SANITARY DISTRICT**

SANITARY DISTRICT  
ACCEPTED MATERIALS

**2019**

PLOTTED ON 7/17/2019  
3:49 PM

**AM 9**

# DUCTILE IRON PIPE (DIP) PRODUCTS

AWWA C150 and AWWA C151, Class 53 wall thickness

## Ductile Iron Pipe

Manufactured in the USA, by one of the following, or approved equal:

1. U.S. Pipe and Foundry Co.
2. American
3. McWane Ductile

## Ductile Iron Fittings

Manufactured in the USA, by one of the following, or approved equal:

1. Tyler Union
2. Mueller Company
3. American

## Protective Lining

Interior surfaces of all ductile iron pipe and fittings shall be lined with one of the following:

1. Protecto 401 Ceramic Epoxy,
2. Tnemec 431 Perma-Shield, or approved equal.

The dry film thickness shall be no less than 40 mils.

## Protective Coating

Buried DIP: asphaltic coating with polywrap

Exposed DIP: Coat per Standard Spec Section 09800, Protective Coatings

Exposed DIP in Wet Wells, one of the following:

1. Tnemec 141, at min dry film thickness of 16 mils
2. US Pipe Ceramawrap, at min Dry film thickness 20 mils

## Polywrap

For all buried ductile iron pipe. Polywrap shall be manufactured by, or approved equal:

1. T. Christy Enterprises.

General purpose adhesive tape to connect plastic film shall be two inches wide by 10 mils thick. Adhesive tape shall be manufactured by, or equal:

1. Scotchwrap No. 50
2. Polyken No. 900
3. Tapecoat CT

## Flange Gaskets:

EPDM, suitable for use with wastewater service.

## Grooved Couplings and Adapters

Rigid type, manufactured by, Victaulic, or approved equal.

**LAS GALLINAS VALLEY  
SANITARY DISTRICT**

SANITARY DISTRICT  
ACCEPTED MATERIALS

2019

PLOTTED ON 7/17/2019  
3:49 PM

AM 10

# INDIVIDUAL LOT PACKAGED PUMP SYSTEMS

**Material Type(s):** Pre-Approved Pump Systems, Pipe

**Description:**

VENDOR	SYSTEM
E-One	D-Series, W-Series, I-Series and G-Series
Liberty	2448- Series, Pro370 Series, Pro380 Series
Aqua Pro Pump Systems	E-Series, EDP Series, ESP-Series, SG-Series, DG-Series

**Note:** Complete packages are required for Pre-Approved Pump Systems. This includes a pump, alarm panel, isolation and check valves, sump and sump extensions (as required). Individual parts of Pump System are not pre-approved by the District. Models include but are not limited to the ones below, contact the District for special approval of all others.



**E-One Model  
D-H071**



**Liberty  
2448 Series**



**E-One®  
Model Gator**



**Liberty® Pro370 Series  
(2" discharge system,  
required Access Driver)**



**Liberty® Pro380 Series  
(2" discharge system,  
required Access Driver)**



**Aqua Pro  
SG-1182-2**

**LAS GALLINAS VALLEY  
SANITARY DISTRICT**

SANITARY DISTRICT  
ACCEPTED MATERIALS

**2019**

PLOTTED ON 7/17/2019  
3:49 PM

**AM 11**